

Component
Technologies



Radio
Technologies



System and Network
Architecture



Network OA&M and
Service Enablement



Trustworthiness –
Security, Reliability,
Privacy, & Resilience



6G

Next G Alliance Report:
6G Technologies

TABLE
OF
CONTENTS

1	Introduction	4
1.1	6G Technology Innovation Needs	4
1.1.1	From Applications/Requirements Perspectives	4
1.1.2	From Spectrum Perspectives	6
1.1.3	From Green G Perspectives	6
1.1.4	From SEN Perspectives	7
1.2	Scope	7
1.3	About the Next G Alliance	7
2	Component Technologies	8
2.1	Semiconductor Technology	8
2.2	Circuits and Subsystems	9
2.3	Antenna, Packaging, and Testing	10
2.4	Holographic Technologies	11
2.5	Section Summary and Recommendations	12
3	Radio Technologies	13
3.1	Basic Radio Technologies	13
3.1.1	THz/Sub-THz	13
3.1.2	Spectrum Sharing	15
3.1.3	mmWave Enhancements	16
3.1.4	Advanced MIMO Technologies	17
3.1.4.1	Low-Frequency Band Enhancement	17
3.1.4.2	Advanced Massive MIMO	18
3.1.4.3	Massively Distributed MIMO	20
3.1.4.4	Reconfigurable Intelligent Surface (RIS)	21
3.1.5	Holographic Beamforming and Orbital Angular Momentum (OAM)	22
3.1.6	Advanced Duplexing Technology	22
3.1.7	Seamless Mobility	23
3.1.8	Waveform, Coding, Modulation, and Multiple Access Schemes	24
3.2	Radio Technologies for Green Communications	25
3.2.1	Green Networks and Ultra-Low-Resolution Communications Systems	25
3.2.2	Device Power Saving	27
3.2.3	Near-Zero Energy (NZE) Communications	27
3.3	Radio Technologies for Advanced Topology and Networking	29
3.3.1	UE Cooperative Communications	29
3.3.2	Non-Terrestrial Network (NTN) and Communications	30
3.3.3	Radio for Extreme Networking: Industrial, In-Vehicle, In-Body, and Intra-Body	31
3.3.4	Mesh Network and Sidelink	32
3.4	Radio Technologies for/by AI and Distributed Cloud	33
3.4.1	AI-Native Air Interface	33
3.4.2	Air Interface Enablement for Distributed Computing and Intelligence across Device and Network	34

TABLE
OF
CONTENTS

3.5	Radio Technologies for Communication-Sensing Fusion	35
3.5.1	Joint Communications and Sensing (JCAS)	35
3.6	Section Summary and Recommendations	37
4	System and Network Architecture	38
4.1	Non-Terrestrial Networks (NTN)	38
4.2	RAN Topologies – Mesh and Sidelink	39
4.3	Architecture Enhancements for Ambient Intelligence (AmI)	40
4.4	Network Disaggregation	40
4.5	UE-RAN-Core Architecture	42
4.6	Distributed Cloud Platform	43
4.7	Applications of AI/ML in Networks and Devices	44
4.8	Lean Protocol Stack	45
4.9	Embedded Subnetwork Connectivity	45
4.10	Enhancements to Application Frameworks/Interfaces and Dynamic QoE Provisioning	46
4.11	Section Summary and Recommendations	47
5	Network Operations, Administration and Management (OA&M), and Service Enablement	48
5.1	Service Management/Orchestration, Data Management, and AI/ML-based Intelligent Network Controller for Automation	48
5.2	Public Safety in Emergencies and Disaster Scenario	49
5.3	Technology Enablers for Business Services Transformation	51
5.4	Energy-Efficient Green Network	52
5.5	Section Summary and Recommendations	53
6	Trustworthiness – Security, Reliability, Privacy, and Resilience	55
6.1	PHY/MAC Security	55
6.2	Quantum Security and Post-Quantum Cryptographic Techniques	56
6.3	Confidential Computation and Storage for Proprietary AI Models for Network Clouds	58
6.4	Data Provenance	58
6.5	Secure Identities, Data, and Protocols	59
6.6	Automated Closed Loop Security Creation	60
6.7	Security Assurance and Defense	61
6.8	Service Availability Enablers	62
6.9	Section Summary and Recommendations	64
7	Summary	65
8	References	67
9	Abbreviations, Definitions	69

1 INTRODUCTION

This Next G Alliance (NGA) report provides expert recommendations about which technologies will be key to 6G and where further research is needed. Technology without a purpose is just a novelty. In order to understand how 6G will be used, views were gathered from experts in the areas of:

- > Applications and Requirements
- > Spectrum Perspectives
- > Green G Perspectives
- > Societal and Economic Needs (SEN)

Forty-seven technological areas were identified spanning the domains of:

- > Component technologies
- > Radio technologies
- > System and network architecture
- > Network Operations, Administration, and Maintenance (OA&M) and service enablement
- > Trustworthiness: security, reliability, privacy, and resilience

Although many of these technologies are starting to be discussed in 5G, they will likely not reach their full potential until 6G. Others represent fundamental departures from 6G's concepts and architectures. Discussions of 6G are just starting, and although some of these research areas may not work out, most will.

These are the technologies that the NGA believes will be key for 6G. Having North America take a leading role in developing these technologies will ensure that the region is a leader in 6G.

1.1 6G Technology Innovation Needs

1.1.1 From Applications/Requirements Perspectives

One of the most commonly agreed ways to identify and analyze customer demand is to consider new types of services. This will provide a good estimation of which new use cases and applications are deemed necessary and therefore what kind of service requirements are needed to support these new use cases and application through 6G systems. NGA has identified four foundational areas of 6G use cases, with a keen focus on how 6G enabling

technologies can help improve everyday living, as illustrated in Figure 1.1.1:

- > **Everyday Living:** How to improve the quality of everyday living.
- > **Experience:** How to improve the Quality of Experience (QoE) in areas such as entertainment, learning, and health care.
- > **Critical Goals:** How to improve the quality of critical roles in sectors such as health care, manufacturing, agriculture, transportation, and public safety.
- > **Societal Goals:** How to attain and improve on high-level societal goals.



Figure 1.1.1: Four Foundational Areas of 6G Use Cases and Applications

Use cases that play key roles in these foundational areas are classified into four categories:

- > Network Enabled Robotics and Autonomous Systems perceive their surroundings using sensors such as Global Positioning System (GPS), Light Detection and Ranging (LiDAR), sonar, radar, and odometry.
- > Multi-Sensory Extended Reality (XR) is the umbrella term for the collection of immersive technologies that include things like Virtual and Augmented Reality (VR/AR).
- > Distributed Sensing and Communications use cases and categorization include sensors tightly integrated with communications to support autonomous systems.
- > Personalized User Experiences are real-time, fully automated, and secure personalization of devices, networks, products, and services based on a user's personal profile and context information (e.g., user's preferences, trends, and biometrics).

Use Case Categories	Use Case Examples	Characteristics of Requirements
Network Enabled Robotics and Autonomous Systems	<ul style="list-style-type: none"> > Online cooperative operation among a group of service robots. > Field robots for hazardous environments. 	Synchronization precision, reliability, end-to-end latency, availability, privacy, security, trust, Artificial Intelligence/ Machine Learning (AI/ML) support.
Multi-sensory XR	<ul style="list-style-type: none"> > Ultra-realistic interactive sports (e.g., drone racing). > Immersive gaming and entertainment. > Co-design merged reality. > Mixed Reality (MR) telepresence and teleportation. > Immersive life (education, health care, retail, etc.). 	End-to-end latency, jitter, experienced data rate, availability, edge computing.
Distributed Sensing and Communications	<ul style="list-style-type: none"> > Public safety applications. > Remote-area data collection, a scenario that includes sensors tightly integrated with communications to support autonomous systems. > In-body networks for health care. 	End-to-end latency, experienced data rate, availability, positioning accuracy.
Personalized User Experiences	<ul style="list-style-type: none"> > Personalized hotel experiences such as real-time automated guest assistance, virtual hotel concierge, and automated room service. > Personalized shopping experiences such as immersive product demos, gamification of retail experiences. 	End-to-end latency, experienced data rate, availability, privacy, security, AI/ ML support.

Table 1.1.1: 6G Use Cases and Requirement Characteristics

1.1.2 From Spectrum Perspectives

With new services and applications towards 6G, more spectrum is required to accommodate 6G innovation. To fulfil these needs, further studies are necessary into the novel usage of spectrum between 7 to 24 GHz, along with an extension to upper Millimeter Wave (mmWave) frequency bands with much broader channel bandwidth. The smart utilization of multiple bands and improvement of spectrum efficiency through advanced technologies will be essential in achieving high throughput over limited bandwidth.

Figure 1.1.2 shows potential spectrum bands for 6G and key technologies that can impact different spectrum related aspects. The bands shown in Figure 1.1.2 are potential candidates for 6G because at this point, no bands are designated for 6G use. The 7 to 24 GHz range can leverage massive Multiple-Input and Multiple-Output (MIMO) technology to ensure good coverage, improve capacity relative to the legacy frequencies between 3 to 5 GHz, and provide a control plane for upper mmWave and Terahertz (THz) frequency ranges. mmWave and THz spectrum, on the other hand, can be considered for providing high data rates and enabling accurate localization and sensing. Technologies like smart repeaters and Reconfigurable Intelligent Surfaces (RIS) can play an important role in improving coverage at upper mmWave and THz frequency ranges. These frequency ranges also enable high resolution and accurate sensing/positioning applications. Cell-free MIMO makes network economics conducive for deployment in the mmWave portion of the spectrum.

into spectrum access. I-Q samples can be directly processed using AI/ML processing to quickly identify the corresponding network and its operating spectrum band.

In 6G, large bandwidths are needed to support extremely high data rates and high-resolution sensing requirements. Availability of contiguous spectrum is preferred, as spectrum fragmentation limits the achievable data rates and ranging resolution. To avoid spectrum fragmentation, efficient spectrum-sharing mechanisms will be required between multiple service providers. Innovative coexistence techniques could be considered between 6G systems and incumbents, with considerations for protection of passive services. Efficient spectrum sharing can help mitigate interference among overlaid deployments, enabling spectrum re-use among licensees. Spectrum-sharing innovations that leverage burstiness of higher priority traffic could help improve spectrum utilization. Disaggregated network architecture can help in efficient reuse of network resources (e.g., sharing of radio units) and can also be used for improving performance with new spectrum-sharing techniques.

1.1.3 From Green G Perspectives

Every new generation of cellular communications has striven to be more energy efficient, especially because traffic growth works against an overall reduction in energy consumption. Moreover, the impetus of climate change demands more from 6G than just reduced energy consumption. In addition to significantly reducing Greenhouse Gas (GHG) emissions to mitigate global warming, it is important for 6G systems

to address biodiversity loss, pollution, and a fundamentally sustainable approach to raw and rare materials. The imperative of a sustainable 6G system also is not merely an environmental one. A sustainable 6G system should transform societies and improve quality of life through

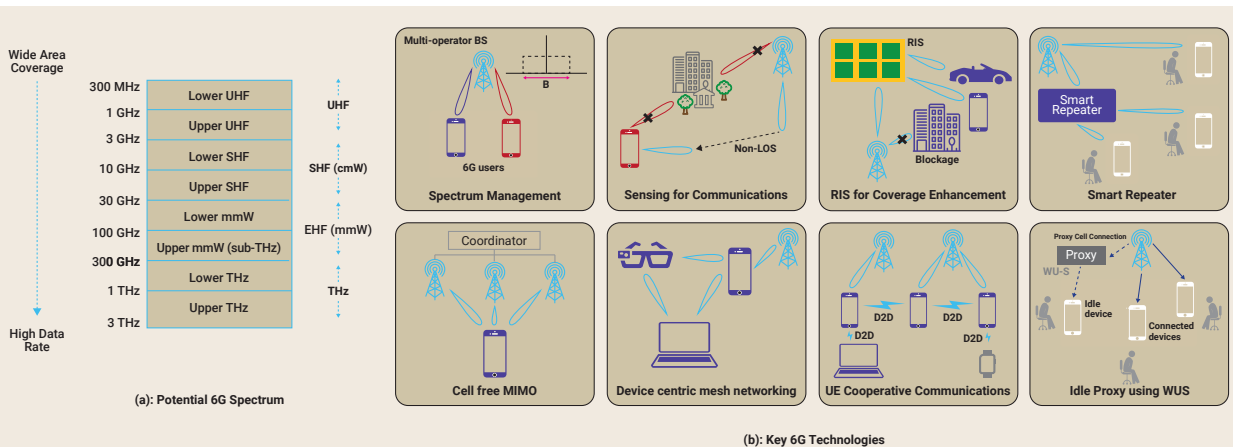

Figure 1.1.2: 6G Spectrum and Key Technologies with Spectrum Implications

A suitably chosen universal low frequency band can help create a universal wake-up signaling mechanism, which can help improve device power efficiency. Furthermore, multi-operator-enabled proxies can be configured to receive wake-up signals on behalf of different devices in indoor settings. Spectrum sharing between sub-networks can help accomplish cooperative communications between different devices. Spectrum sharing at high frequency ranges can also help enable mesh networking, thereby offloading traffic from access network, and thus improving spectrum usage. AI/ML techniques can be used to bring in an element of cognition

better health, food and water security, and reduced inequality, and benefit businesses and the economy through growth, innovation, and infrastructure resiliency. As with previous generations of mobile networks, many industries will depend on 6G. Therefore, 6G needs to be sustainable to help other industries reach their targets. In addition to the network's inherent sustainability, 6G should enable any industry to become more sustainable by means of monitoring GHG emissions, improving waste management, helping implement circular economy principles, and so forth.

In achieving the aforementioned goals and making North America a global leader, it is important to define specific metrics and corresponding targets for the complete lifecycle of the entire 6G system [1]. For hardware components, sustainability begins in the design process, considers manufacturing and the supply chain starting with material sourcing and mining, and ends with waste management of obsolete and possibly toxic components. Likewise, operational aspects need to account for all elements of the network spanning the air interface, User Equipment (UE), compute and storage infrastructure, system and network architecture, and OA&M. To ensure specified targets are indeed met, 6G systems need to enable the observability of said metrics, which, moreover, can help rate products for their environmental impact, educate consumers, and ultimately influence their purchasing behavior in favor of the environment.

When everything is considered holistically and optimized in concert, such as the radio access network's increased energy efficiency aids the reduction in GHG emissions, the data center improves its use of land and water resources, AI/ML optimizes the network operation, the zero-energy device alleviates the impact of its battery on the environment, circular economy principles pervade manufacturing, and policy incentivizes recycling and stimulates research through tax subsidies, infrastructure funding, research grants. Only then will 6G fulfill its vision and promise for a more sustainable future.

1.1.4 From SEN Perspectives

There is a symbiotic relationship between technology and a population's societal and economic needs. As technology shapes human behavior and lifestyles, those needs in turn shape technological evolution. There is an imperative to incorporate environmental, social, and economic factors throughout the full 6G lifecycle of research and development, manufacturing, standardization, and market readiness. Taking into account societal and economic needs it yields a better, innovative solution while also enabling progress toward five crucial outcomes for society around digital equity, trust, sustainability, economic growth, and improved quality of life.

Table 1.1.4 reflects a base inventory of social and economic issues that, when addressed, will result in corresponding outcome for society. As the NGA's efforts continue, it is expected that future areas for research and technology investment will be further identified and defined.

Outcome	Related Issues Include, but Not Limited to
Digital equity	Affordability, Accessibility, Geographic Availability
Trust	Security, Data Privacy, Resiliency
Sustainability	GHG Emissions, Sustainable use of energy, water, land, and materials across the entire value chain for 6G telecommunication infrastructure
Economic Growth	Manufacturing and supply chain, Workforce Development
Quality of Life	Health Care, Education, Safety and Security, Environment

Table 1.1.4 Base Inventory of Social and Economic Issues

1.2 Scope

The scope of this report is to provide an overview of identified 6G candidate technology and research areas to contribute to and to influence the 6G vision, technology roadmap, and Research and Development in North America. This includes the following five technical areas, along with recommendations on 6G research focus areas:

- > Component Technologies
- > Radio Technologies
- > System and Network Architecture
- > OA&M and Service Enablement
- > Trustworthiness

1.3 About the Next G Alliance

The NGA is a bold new initiative to advance North American wireless technology leadership over the next decade through private-sector-led efforts in association with government stakeholders. With a strong emphasis on technology market-readiness, the work will encompass the full lifecycle of research and development, manufacturing, standardization, and market readiness.

2 COMPONENT TECHNOLOGIES

Semiconductor technology has driven transformative advances in nearly every modern technology, from computing to mobile phones to the Internet. It plays a critical role in many areas of our society and economy, such as transportation, medical technology, communications infrastructure, and defense. Microelectronics is expected to underpin advances in future “must-win” technologies including AI and future advanced wireless networks (6G).

Currently the semiconductor industry employs nearly 300,000 workers in the U.S. and indirectly supports nearly 2 million jobs [2]. Semiconductors are America’s fourth largest export, with wireless technology one of its most important sectors [2]. Continued North American leadership in semiconductor technology and the associated supply chain goes hand-in-hand with building a leading position in 6G.

This section reviews the key microelectronics technologies anticipated to be required for 6G wireless communications.

2.1 Semiconductor Technology

Semiconductors are the enablers of digital wireless communications. Information and signal processing occur in digital, analog, and Radio Frequency (RF) domains, leveraging the unique capabilities of disparate semiconductor technologies that range from billions of transistors in advanced Complementary Metal-Oxide-Semiconductors (CMOS) baseband processors to Power Amplifiers (PAs) and low noise amplifiers in compound semiconductor or specialized silicon technologies for RF signal amplification at the antenna interface. To achieve 6G network Key Performance Indicators (KPI) for extreme data rates, higher spectral efficiency, and better energy efficiency, semiconductor technology will require innovation that improves the performance, power consumption, and density of the digital, analog/mixed signal, and RF ICs that constitute the 6G radio.

The Sub-Terahertz (sub-THz) frequency bands from 100 to 300 GHz are attractive candidates for 6G due to the large available spectrum bandwidth at these frequencies that can be exploited to achieve data rate and sensing goals. Semiconductor technologies with device performance $>500 \text{ GHz } f_t / f_{\text{max}}$ and with cost and scale to enable high-volume wireless consumer and infrastructure markets are prerequisites for the successful utilization of this spectrum. At frequencies above 300 GHz, opto-electronic technologies will come into play. In addition, spectrum allocation in the 8-20 GHz range is desired for wider coverage, with evolution of RF semiconductors optimized for $<6 \text{ GHz}$ front ends to meet performance requirements of these middle frequency bands. At higher frequencies above 300 GHz, opto-electronic technologies will come into play. In addition, spectrum allocation in the 8-20 GHz frequencies is desired for wider coverage, with evolution of RF semiconductors optimized for $<6 \text{ GHz}$ front ends to meet performance requirements of these middle frequency bands.

Fundamentally, semiconductor device performance, as determined by unity current and power gain frequencies (respectively f_t and f_{max}), will need to be a minimum of 3x to 5x the wireless carrier frequency for realization of radios with acceptable range, power dissipation, and link margin. In the transceiver and RF Front End (RFFE), moving to 100-300 GHz carrier frequencies will therefore require semiconductor technologies with f_t / f_{max} in range of 0.5 THz to $>1 \text{ THz}$.

Silicon and III-V semiconductors are candidate technologies, with advances in Silicon Germanium (SiGe) and Indium Phosphide (InP) roadmaps promising $>1 \text{ THz}$ performance. The two central challenges are achieving the high frequency performance needed for efficient broadband performance at sub-THz frequencies and reaching the cost and scale needed for high volume market adoption. Silicon technologies today have the cost and scale for volume markets but are challenged on performance above 100 GHz, resulting in circuits with low gain, low output power, low efficiency, and higher noise figure. Scaling to more advanced nodes exacerbates these issues due to the impact of parasitics and gate resistance of advanced node CMOS. Advances in SiGe Bipolar CMOS (BiCMOS) seek to increase silicon transistor performance without sacrificing silicon cost and scale. Compound semiconductor technologies such as InP and Gallium Nitride (GaN) have requisite performance at sub-THz but are fabricated on small substrates, have limited logic integration, and lack volume and scale, resulting today in high cost. Research into monolithic integration of compound semiconductor transistors on silicon substrates, as well as advances in heterogeneous integration of compound semiconductors and silicon, all look to address the cost and scale issues without sacrificing performance.

Foundational to utilization of the sub-THz/THz spectrum for 6G are semiconductor technologies with $>500 \text{ GHz}$ performance and the scale and cost to enable high-volume wireless markets.

The complex 6G puzzle will be solved only when all individual pieces, designed as best in class in the most appropriate technology, fit in the optimal architecture.

2.2 Circuits and Subsystems

The objective of achieving extremely high data rates with low power consumption in 6G can be realized only by employing the wide bandwidths available at mmWave frequencies. These frequencies were considered out of reach for mobile applications not so long ago, but thanks to modern technologies (Section 2.1) communication systems can now effectively move to higher mmWave frequencies. This comes with a multitude of challenges. Complex architectures and algorithms will feed the high data throughput and provide beamforming to deal with the specificity of the mmWave propagation channels. They will have to be supported by high-performance and power-efficient hardware, both in the digital and in the analog domain. Today, several North America companies have the lead in 5G transceiver design. Nevertheless, continued innovation is needed as the complex 6G puzzle will be solved only when all individual pieces, designed as best in class and in the most appropriate technology, fit in the optimal architecture. This section advises on the needed research for RF/mmWave transceivers including the front end (e.g., PA, Low-noise Amplifier (LNA)), Local Oscillator (LO) generation and up/down-conversion, analog baseband, data converters, power management, and digital circuitry.

Moving to the sub-THz/THz range in 6G comes with unprecedented challenges, both from the architectural and the circuit points of view. The optimal beamforming architecture for mmWave communication at these frequencies needs to be investigated. This obviously impacts circuit design because the requirements and circuit specifications will be influenced by the corresponding architectural choices. The design of these circuits will be extremely challenging due to the envisaged data throughput, the wide bandwidths, and the high RF operating frequency. This will require best-in-class performance for all the individual sub-blocks, which will be designed in appropriate technologies to provide the performance needed (Figure 2.2). Indeed, the margin between the requirements and the technology limits is lower than ever before. To merge these building blocks, 6G research will therefore also need significant advances in packaging.

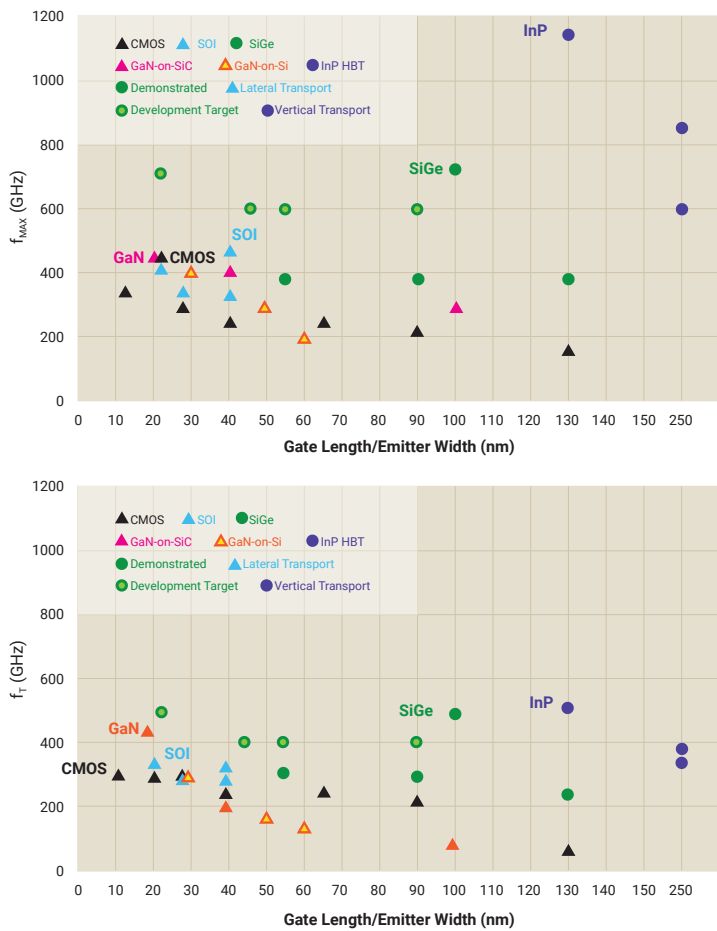

Figure 2.1: Transistor maximum oscillation frequency f_{max} (upper) and cut-off frequency f_T (lower) vs. technology node/emitter critical dimension. CMOS plateaus < 500 GHz. SiGe and InP HBTs have demonstrated f_T/f_{max} of 500 GHz/700 GHz [3] and 520 GHz/1.1 THz [4], respectively

In the digitally intensive baseband, continued progress is needed in the “Angstrom” era of CMOS to keep up with demands for low power compute and signal processing. Advances in the analog/mixed signal and RF capabilities of these CMOS nodes are also important for low-power data conversion at 6G’s extreme data rates and for low-power broadband 8-20 GHz MIMO transceivers.

6G semiconductor leadership in North America will require investment in both THz-class and Angstrom-Era semiconductors. North America has a strong position in high-performance RF today. However, 6G leadership will require investments in extending SiGe performance to 1 THz and in radically improving the cost, scale, and integration of InP and GaN. The Defense Advanced Research Projects Agency (DARPA) has started to seed this development with the T-MUSIC and ELGAR programs, respectively. In high-volume, cutting-edge CMOS, there is a gap, and significant investment is needed to regain leadership.

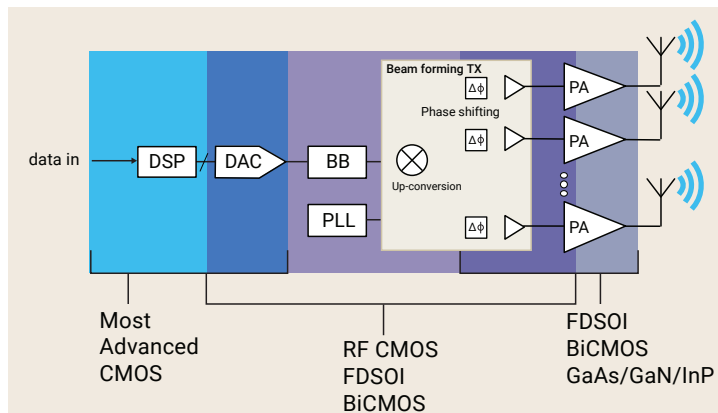

Figure 2.2: Block diagram of a sub-THz-band transmitter featuring various technologies for the various sub-blocks. A similar block diagram can be drawn for the receiver.

Various research areas are important to make 6G a reality. At the base lies the architectural choice. Various beamforming architectures are possible such as digital or analog based, the latter providing phase shifting in baseband, RF, or LO. It will be important to understand these topologies correctly as they will impact the specifications and as such the feasibility of the various components. Significant research is needed into the various transceiver components. This starts from the digital platform, where efficient algorithms will be implemented in the most advanced CMOS nodes.

Moving to the analog domain will require data converters (e.g., Analog-to-Digital Converter (ADC) and Digital-to-Analog Converter (DAC)) with extreme sampling rates and resolution. To support the GHz signal bandwidths, new data converters combining high sampling speeds with high resolution are needed. This results in a new family of data converters, next to the existing giga-sample converters, which are typically aimed at wireline applications and lack sufficient resolution. To be competitive and fit in a compact area, their power consumption will have to be further reduced compared to existing state of the art [5]. Research on the analog baseband is also important because of the need for bandwidths up to tenfold of what are common today.

Moving to the actual RF region, low phase noise frequency synthesis and LO distribution are key challenges to be solved for D-band operation. The phase noise integrated over the large signal band should be compatible with the complex modulation schemes aimed for. This is even more challenging because the LO will typically be generated at a lower frequency to obtain sufficient tuning range and limit the losses in the distribution and the subsequent frequency multiplication results in increased phase noise.

Finally, the RF circuits are key for mmWave communication. The receiver will need wideband LNAs. The biggest challenge lies on the transmit side, where the PA will need to combine wide bandwidth with high linearity and high efficiency to modulate complex signals with sufficient output power. Note that efficiency is important not only for environmental concerns but is also fundamental for the feasibility of packaging transmitter arrays in a very limited form factor. CMOS PAs will not provide sufficient power efficiently, so alternative technologies such as SiGe or III-V materials such as Gallium Arsenide (GaAs), InP, and GaN will be used [6]. Although several North American companies are already active in these fields, they typically do not target the consumer market. To be successful, these technologies will have to be matured at the same level of CMOS for them to be commercially competitive. Modeling, flexibility, yield, and PDK support will have to be improved to create a commercial-oriented ecosystem and enable the realization of complex RFFE. To bring everything together, the interaction between circuit design, technology development, and modelling on the one hand and the co-design of circuits with antenna and packaging will also be key in the 6G circuits and systems research. But technology does not stand on its own. North American universities will have to provide the electrical engineers,

particularly analog and RF circuit designers, which combine theoretical circuit and technology insight with an extensive experience and a certain amount of intuition.

2.3 Antenna, Packaging, and Testing

The antenna is the interface between the propagating electromagnetic waves and the electrical power used with the transmitter and the receiver. Subcomponents such as integrated circuits, passives, and antennas need to be packaged into sub-assemblies and modules to meet requirements for reliability, mechanical stability, electrical performance, size, and cost goals. This is achieved by a wide range of packaging technologies.

Ultimately, to deliver products in either prototype or high-volume production, solutions are needed for verification/conformance, production testing, and calibration.

While basic semiconductor technologies will continue to make progress, the role of advanced packaging will be increasingly important in meeting the requirements of 6G to integrate into the required form factors with heavily constrained power budgets. Heterogeneous integration is needed to address the requirements for high-speed and power-efficient computing, signal processing, sensor integration, and the RFFE [7]. Advanced packages using 2.5D and 3D topologies will require continued development of substrates, 3D interconnect (e.g., Through Silicon Via) and ultra-fine pitch bumps for chip-to-wafer and wafer-to-wafer bonding. New materials will need to be explored, along with advancing equipment and metrology capabilities. Finally, new design flows are needed to allow package/die co-design, simulation, and modeling considering electromagnetic, mechanical, and thermal effects while ensuring reliable operation and high manufacturing yield.

The anticipated use of higher frequencies, multi-antenna technologies, and wider bandwidths in 6G will require the development of new concepts in antenna design and integration. This includes Antenna-on-Chip (AoC)/AiP for mmWave and sub-THz frequencies, as well as innovation at lower frequencies, novel materials (e.g., metamaterials), and electronically controllable antennas. These will be important, for example, in achieving full duplex operation and RIS.

For 150 GHz, the maximum antenna element-to-element spacing is 1 mm. The interconnect density and thermal challenges are significant with such high-density antenna arrays. Figure 2.3 summarizes this challenge.

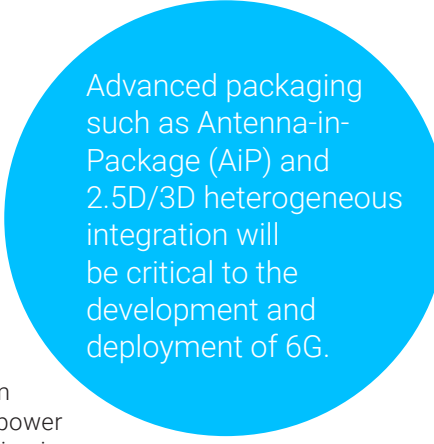

Advanced packaging such as Antenna-in-Package (AiP) and 2.5D/3D heterogeneous integration will be critical to the development and deployment of 6G.

Tiles:
 Thinner and cheaper
 Less space to fit the electronics
 More difficult to remove the heat

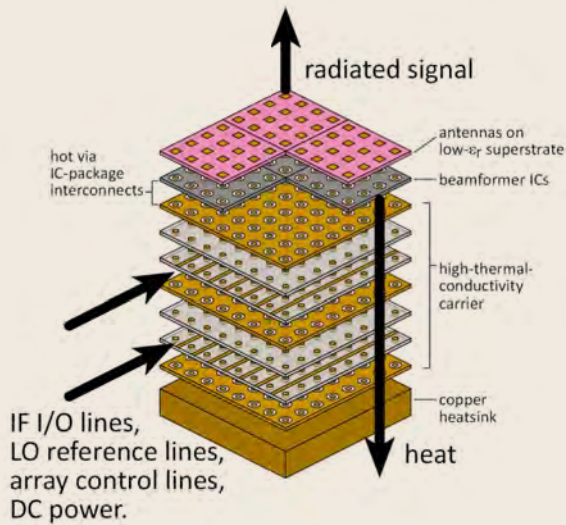

Trays:
 Thicker and more expensive
 More space to fit the electronics
 Easier to remove the heat

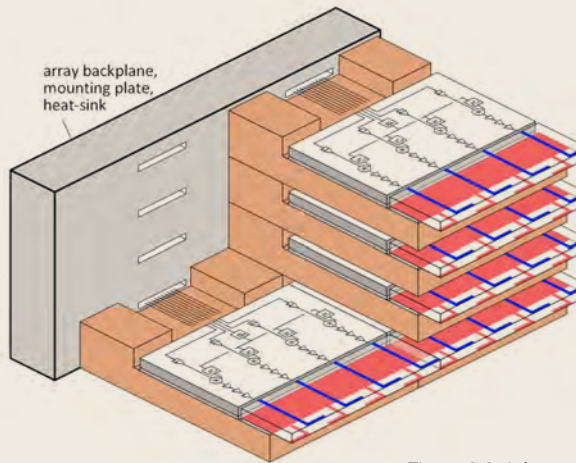

Figure 2.3: Advanced packages are required for >100 GHz systems [8]

Continued development of passive technologies, both discrete and integrated, is also needed for anticipated 6G devices and equipment, both reducing the size and increasing performance. Focus is required on RF filters, capacitors/inductors, duplexers/circulators, and novel devices such as those utilizing MEMs.

In the context of North American leadership, it is important to note that the packaging industry is one of economies of scale and that the long-term trend has been the movement

to offshore manufacturing. Advanced packaging requires sophisticated tools and materials. There is a critical need for cost-effective, smaller volume prototype access for research groups and universities.

North America has significant capabilities in many of the key technology areas around antenna and packaging technologies, such as those developed under DARPA programs. For leadership in the 6G era, these capabilities need continued ongoing investment and scaling up for commercial deployment in volume.

2.4 Holographic Technologies

The combination of holography and the tactile Internet is considered the holy grail of personal communication systems and 3D displays. This is primarily because holography is the only technology that can provide all of the necessary cues (monocular and binocular in terms of parallax and depth) for human visual interpretation when compared to any other visual representative scheme. Although 5G showcased the ability to make and sustain holographic calls, 6G can pave the way to make this technology more mainstream while also providing enormous economic opportunities through integration into other services such as tactile Internet to provide true no-travel experiences.

Holography is the holy grail of personal communication systems. 6G can help take this technology to everyone's doorstep.

Table 2.4 shows the typical data rates needed to sustain holographic calls in comparison to other past and present video communication technologies.

Video Communication Type	Bandwidth Requirement
HD	1-5Mbps
4K 360°	15-25Mbps
16K 360°	100-500Mbps
Point Cloud Holograms	0.5-2Gbps
Light Field Holograms	~ 1Tbps

While holography consists of the three steps of generation, transmission, and reconstruction of brightness and phase of light waves, considerable challenges exist. Investigations into the relevant security, privacy, computation, compression, and transmission technologies are needed to make them mainstream. These are different from current conversational traffic and 2D image transmissions due to their needs of extremely high data rates and zero-loss transmissions while still being able to support the computational complexity needed on the client and/or server devices.

While considerable research is taking place in display technologies, further efforts are needed into making holographic displays applicable for the handheld form factors users have come to love. These current challenges should lead to research that can eventually support both thick (local computation at the client) and lean client (local computation with a receiver site with the client as just a display) [10] models of computation and transmission. Further, the ability to transmit the required multi-Gbps bandwidths to multiple users at the same time in both broadcast and unicast modes is needed.

Challenges are also present in terms of being able to replace existing research activities that need live beings with holography in terms of user interface and the additional training for transitioning between virtual and real worlds. Another area of research is display technologies that balance power efficiency with safety, especially in relation to the use of lasers typically found in holographic capture and projections. This work should include identifying the enhancements needed in terms of privacy with holographic displays in public places and understanding the associated civic impact of integrating holographic images into real-world scenarios (e.g., office rooms, tactile Internet, and AR/VR scenarios) to provide truly realistic no-travel (teleport) interaction scenarios in the future.

With North America being at the forefront of privacy and security laws, green technologies, university-driven research programs, and federal and state initiatives, efforts have already begun during the Covid-19 pandemic to move toward a more digital, no-travel future. Though AR/VR is one such direction, it often comes with bulky and cumbersome equipment with limited interactions. Holography is uniquely positioned to enable a no-travel, interactive future while providing enormous opportunities to impact education, consumer, and enterprise scenarios.

2.5

Section Summary and Recommendations

Advanced component technologies will underpin 6G. The most important of these technologies is semiconductors due to their strategic importance across multiple industries and sectors. Leadership in this area includes basic material and device science, circuits and systems, and large-scale advanced manufacturing capabilities.

The key recommendations in this area include:

- > **Increased investment in semiconductor research.** U.S. leadership in semiconductors is key to being competitive in the 6G era. Significantly increase federal investment in research pertaining to the use of microelectronics for advanced wireless communications.
- > **Incentives for manufacturing to spur economic growth and strengthen the resilience of the supply chain for critical infrastructure such as 6G.** Provide targeted grants and tax incentives for the construction of new onshore advanced semiconductor and packaging research and manufacturing facilities.
- > **Workforce development.** Implement national strategies to increase the number of students graduating in STEM fields and create a talent pipeline to fulfil the workforce requirements for the development of advanced semiconductor technologies.

Additionally, 6G will require advanced 3D display technology (holographic capability) and continued advancements in semiconductor packaging, RF components, and antennas. Recommendations here are to invest in basic research for developing advanced prototypes, as well as securing access to the required manufacturing capability to be in place when 6G reaches full commercial scale.

3 RADIO TECHNOLOGIES

Radio technologies enable communication between UEs and networks. They are the most fundamental and essential part of any wireless system.

This paper first discusses basic radio technologies having direct impact on canonical system KPI such as spectral efficiency, throughput, and latency. This includes technologies enabling the use of newly available extremely high frequencies such as sub-THz/THz bands, as well as technologies enhancing the current use of mmWave bands. Spectrum sharing and full duplex are also equally important technologies to achieve more efficient use of existing low and mid-band spectrum. This section also discusses various MIMO technology enhancements envisioned for 6G, including advanced massive MIMO, distributed MIMO, RIS, holographic beamforming, and OA&M technologies. It also explores enhancements to waveform, coding, modulation, multi-access scheme, and mobility enhancement for 6G.

Radio technologies for more energy-efficient and green networking are becoming increasingly important in 6G. This includes energy-saving solutions for both the network and the device.

Conventional cellular networks assume fixed network topology, so the connectivity between the device and the network has been the primary focus of system design. In 6G, it is expected that radio technologies for advanced topology and networking — such as UE cooperative communication, Non-Terrestrial Networks (NTN), and mesh networking — will play more critical roles to support various non-conventional types of connectivity, as well as continuously evolving network topology to adaptively meet the varying traffic demand. New topology and networking to support extreme industrial and commercial use cases are also considered as an important part of 6G to promote new business opportunities.

AI-based air interface design and air interface enablement for distributed computing and intelligence are recent new areas of radio technology and considered to play an important role in 6G. Through these technologies, 6G can achieve holistic end-to-end system optimization, seamless automation, and true convergence of communication and computing.

Last but not least, radio technologies enabling sensing for situational awareness are instrumental to newly emerging use cases such as autonomous driving, XR, and interactive gaming. Very wide sensing bandwidth is required for high resolution applications, so higher frequency bands such as mmWave/sub-THz/THz are often considered for sensing. These high-frequency bands are also considered for communication, so by integrating sensing functions into the 6G communication systems, more efficient and cost-effective integrated solutions can fuel the aforementioned use cases in 6G.

3.1 Basic Radio Technologies

For 6G, advances in basic radio technology will continue to provide enhancements to system coverage and capacity performance, all of which will translate into higher user throughputs, higher link reliability, and an overall improved user experience. For 6G, there are several areas in radio technologies that are expected to provide significant performance improvements:

- > 6G expanding into sub-THz frequencies (between 100 GHz and 300 GHz) and THz frequencies (300 GHz to 3 THz). These bands' extremely high bandwidth can enable various use cases not provided by 5G despite having relatively shorter achievable ranges compared to 5G.
- > 6G to be designed with advanced spectrum sharing techniques as a means to better utilize existing spectrum.
- > Massive MIMO technology will continue to evolve and provide significant enhancements to overall system performance and user experience in currently allocated spectrum (e.g., the sub-6 GHz and lower mmWave bands) and in the new 6G bands (e.g., above 6 GHz and sub-THz/THz).
- > Full duplex technology as a means to go beyond the traditional Time Division Duplex (TDD) and Frequency Division Duplexing (FDD) operation in a way that leverages the benefits of both TDD and FDD for enabling higher throughputs, lower latencies, and more flexible scheduling.
- > Advances in mobility management that will enable more reliable and seamless communication in mobility scenarios with interruption-free and robust data transmission and reception across radio technologies.
- > Waveform and multiple access technologies are expected to continue evolving to provide improved coverage, improved power efficiency, higher spectral efficiencies, and higher link efficiencies.

3.1.1 THz/Sub-THz

The abundance of spectrum at sub-THz (100 GHz to 300 GHz) and THz (300 GHz to 3 THz) frequencies can enable new use cases such as holographic services, XR (VR+AR+MR), THz interconnects, data center inter-rack connectivity, Integrated

Access and Backhaul (IAB), applications with high positioning accuracy, critical medical communication, non-invasive health monitoring, smart vehicle keys, peer-to-peer SOS messaging, Device to Device (D2D) based mesh networking, swarm communications (for robots and Unmanned Air Vehicle (UAVs)) and Joint Communications and Sensing (JCAS), as shown in Figure 3.1.1. Enabling such applications would require overcoming associated challenges, namely increased absorption and path loss, beam management due to ultra-massive MIMO antenna arrays, and low efficiency of RF devices.

Requirements of sub-THz/THz devices with different form factors – namely Base Station (BS), UE, wearables, and intra-/inter-chip interconnects – can be vastly different. The underlying design therefore needs to cater to the diverse, and often, competing requirements of these different devices. Factors like array size, DAC/ADC sampling rates and resolution, bandwidth, noise figure, Error Vector Magnitude (EVM), beamforming architecture (e.g., analog, hybrid, or digital), Tx and Reception (Rx) antenna isolation, and PA output power will impact the overall hardware design.

Furthermore, ambient backscatter communication and RIS

can potentially offer new avenues to optimize the underlying hardware's cost and power. New channel models based on stochastic, deterministic, and mixed approaches need to be developed for the different use cases of interest. These channel models need to account for sub-THz/THz frequency specific aspects like propagation characteristics, impairment modeling, and ultra-massive MIMO antenna arrays. Channel sounding experiments at these frequencies need to account for interaction with atmosphere and building materials, along with incorporating effects due to human body parts and other ambient objects. In addition to traditional channel modeling

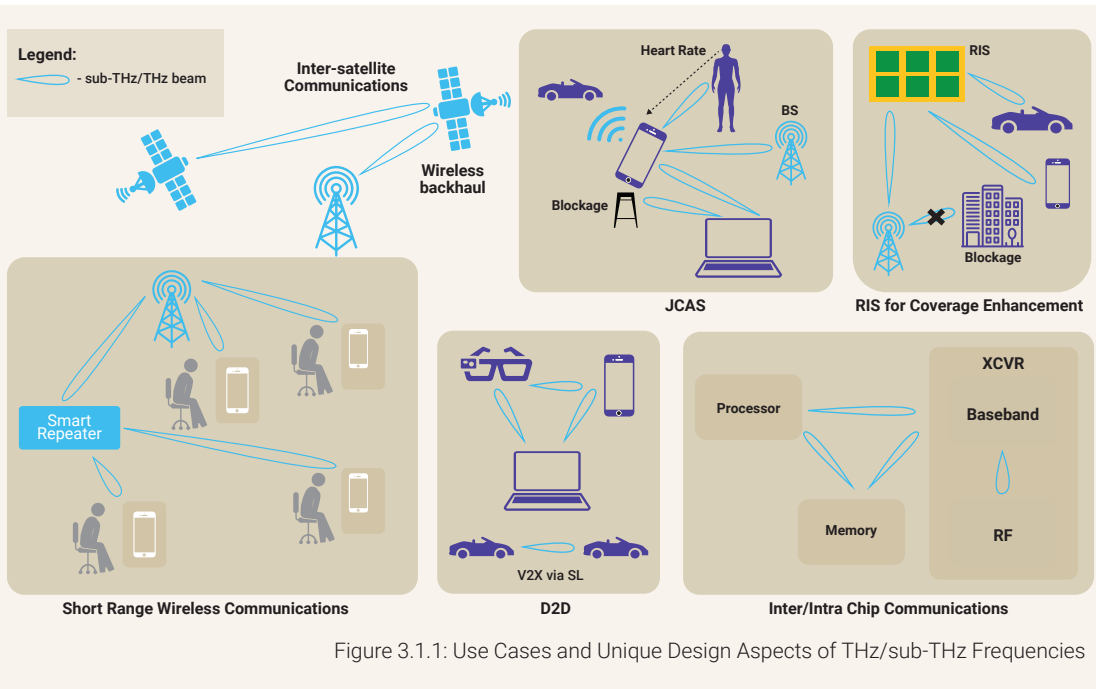

Figure 3.1.1: Use Cases and Unique Design Aspects of THz/sub-THz Frequencies

6G can enable diverse applications like holographic services, XR, JCAS, and THz interconnects by operating at sub-THz/THz frequencies.

The diverse nature of use cases points to varied requirements in terms of throughput, latency, power efficiency, and coverage. Combinations of the aforementioned requirements are needed for certain use cases, while power-efficient design is a common requirement for all of them. For example, XR applications would require ultra-high throughput and low-latency communication links. Specific requirements for each use can be derived by considering factors like operating bands, channel characteristics, and regulatory requirements (which determines the operating Transmission (Tx) power level to ensure co-existence with legacy users of sub-THz/THz frequencies and may determine the channel access needed in each band).

methods, AI/ML based models can be used for multi-path analysis, extraction, and classification of channel model parameters.

New radio technologies need to be explored to meet the throughput, latency, range, topology, and power efficiency requirements of sub-THz/THz devices. Candidate waveforms include, but are not limited to, On-Off Keying, multi-carrier (e.g., Orthogonal Frequency Division Multiplexing (OFDM)), and ones based on SC, (e.g., Discrete Fourier Transform Spread OFDM (DFT-s-OFDM)). Used waveforms need to be optimized to meet the PA characteristics at these frequencies. Apart from Orthogonal Frequency Division Multiple Access (OFDMA), alternate multiple access techniques like Frequency Division Multiple Access (FDMA), Code Division Multiple Access (CDMA), Non-orthogonal Multiple Access (NOMA), and Carrier Sense Multiple Access/Collision Avoidance (CSMA/CA) could be considered. Moreover, innovative single-transmitter multi-receiver modulation and multiple access schemes such as hierarchical bandwidth modulations to support some of the aforementioned applications (e.g., XR) and that can leverage the channel properties might be included. So could hardware-efficient and advanced modem algorithms (e.g., AI/ML-based encoding and

decoding techniques). Radio technologies that support highly pipelined and parallel data processing would be keys to realizing throughputs on the order of Terabits Per Second (Tbps). Adaptive modulation and coding schemes that can respond to bandwidth changes, not just range, would be another key design aspect. In the case of JCAS, a common hardware and waveform design that caters to sensing and communication requirements would be important. Full-duplex operation may be needed for communication and/or sensing. To support full-duplex transceiver operation, novel self-interference measurement and cancellation techniques need to be developed at these frequencies. Beamforming-based cancellers for joint self-interference and multi-user interference cancellation could be another full-duplex aspect of interest. MIMO-related aspects that can be of interest are MIMO beamforming architectures, Multi-user MIMO (MU-MIMO), distributed MIMO, Line of Sight MIMO (LOS-MIMO) and Orbital Angular Momentum (OAM)-MIMO, as well as other wavefronts beyond OAM-carrying Gaussian beams, such as self-healing Bessel beams. To ensure good coverage, features like smart repeaters and RIS could be considered in the network topology for sub-THz/THz. Leveraging benefits at sub-THz/THz frequencies could require higher layer protocol enhancements to realize low latency and robust design.

North America's leadership in key 5G technologies helped achieve Gbps throughputs via deployments in the lower mmWave spectrum. Research on aforementioned areas of sub-THz communications would further extend North American leadership into the next generation and can help usher wireless communications into the Tbps regime. The new use cases and applications enabled by the THz/sub-THz radio technology will improve the quality of life for many people living in these countries and keep the wheels of their economies turning. Moreover, the opened-up opportunities will drive further innovations on high-performance RF devices, and it will maintain North American leadership in this field. Investment in THz/sub-THz research and undertaking-related challenges will also strengthen the position of North America in global standard bodies.

3.1.2 Spectrum Sharing

Finding new spectrum for each next generation of cellular technology is becoming increasingly difficult. Each new generation has sought a wider bandwidth spectrum to meet the needs of increasing peak data volume demands of extremely demanding use cases, which surpass those of the previous generation. It is also no surprise that diverse services compete for use of the more attractive spectrum bands, often pitting incumbent services against commercial wireless' insatiable demand for new spectrum. This means that exclusive licensing is not always feasible. Spectrum sharing is an approach that can be considered to alleviate bandwidth availability constraints for public and private networks. In addition, spectrum-sharing frameworks can also be employed when allocation of exclusively licensed spectrum is not feasible.

Waveform design and procedures of all previous generations of cellular technologies were primarily customized for

deployments in exclusively licensed spectrum. While 4G Long-Term Evolution (LTE) and 5G New Radio (NR) added support for unlicensed spectrum, the newly introduced features required for access in unlicensed spectrum had to build upon the procedures designed for use in licensed spectrum. 6G comes with a clean slate opportunity to consider designs for all deployment scenarios, including exclusively licensed, non-exclusively licensed, and unlicensed spectrum uses. Technology that efficiently shares spectrum can provide economical and societal benefits, such as reduced cost, and new use cases and deployment scenarios. The main challenges for shared-spectrum deployments include (but are not limited to):

- > Predictability of available resources.
- > Efficient system performance measurement.
- > Real-time spectrum sensing in complex rf environments such as mixed rf signals and heterogeneous systems.
- > Management of mutual interferences between networks of the same technology or across different technologies.
- > Interference detection and mitigation techniques.

New research is needed to develop techniques that improve spectrum-sharing efficiency and predictability of radio resources of 6G use in a manner that they approach the performance of exclusively licensed spectrum. For efficient utilization of limited available spectrum, 6G must natively support technology for sharing, including static, semi-static, and dynamic sharing in time, frequency, and spatial domains. Research areas include the study of a variety of scenarios, use cases, and spectrum sharing and system measurement techniques.

Figure 3.1.2 illustrates example scenarios to consider when developing technologies for spectrum sharing. These include sharing among licensees utilizing the 3rd Generation Partnership Project (3GPP) technology for public and/or private networks and accounting for protection of any incumbent users in the band (e.g., fixed point-to-point service, satellite, passive radio astronomy). The coexistence with passive radio astronomy incumbents in sub-THz frequency range needs to be addressed if the required 6G bandwidth exceeds 12.5 GHz [11]. The spectrum may be exclusively licensed, shared in coexistence scenarios that focus on sharing between previous generations and 6G, or locally licensed where spectrum is shared between previous generations and 6G, or 6G only. The unlicensed spectrum is another scenario of interest, which may cover cases of license assisted access and fully unlicensed access schemes. In addition to the coexistence scenarios listed above, coexistence with non-3GPP technologies needs to be considered, as well.



Figure 3.1.2: Examples of spectrum sharing scenarios

6G has to natively support technology for spectrum sharing, including static, semi-static, and dynamic sharing in time, frequency, and spatial domains.

Given the bandwidth requirements for 6G and spectrum status in North America, new spectrum-sharing technologies need to include techniques that should be studied for Super High Frequency (SHF) and Extremely High Frequency (EHF) bands. New channel-access procedures, with or without channel sensing, may be needed to enable efficient sharing with a high degree of predictability of resources among multiple authorized co-primary users or sharing among secondary services and primary users. Sharing may be applicable to different network

topologies (e.g., co-located or distributed, homogeneous or heterogeneous) and may include interference detection, localization, mitigation, or cancellation. Spectrum-sharing procedures should also be considered in conjunction with new system architectures that reduce deployment costs and meet tighter carbon footprint targets for new 6G deployments.

3.1.3 mmWave Enhancements

3GPP Release 15 supports the use of mmWave bands with larger subcarrier spacings and larger channel bandwidths to achieve higher data rates and low-latency transmission. The deployment of mmWave is expanding quite rapidly in parallel with enhancements introduced in Release 16 and 17 and 5G-Adv (Release 18+). This includes support for frequency ranges above 52.6 GHz (up to 71 GHz) with new subcarrier spacings (480 kHz and 960 kHz) and up to 2 GHz channel bandwidth. 6G is expected to continue its evolution by targeting improved coverage, robustness, power efficiency, and spectral efficiencies. Enhancements related to beamforming, beam tracking, and topology, including low-cost densification, are key to this evolution.

6G can build on top of the existing 5G mmWave technologies, along with introducing new technologies to enable cleaner and leaner designs.

Lessons learned from existing 5G mmWave real-world deployments and products provide opportunities for potential improvements. 6G can build on top of the existing 5G mmWave technologies, while introducing new technologies to enable a cleaner and leaner design. However, the higher frequency ranges for mmWave require continued innovations to overcome certain challenges including, but not limited to, significant path loss due to blockage from obstacles, device form factor related optimizations, satisfying maximum permissible exposure requirements, beam management complexity, cost-effective network densification, and improving power efficiency of network and devices.

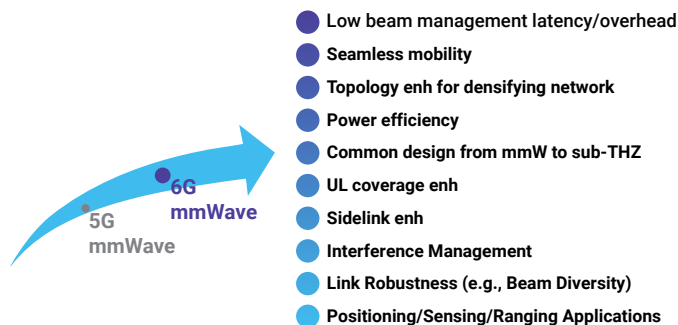

Figure 3.1.3: 5G to 6G mmWave Enhancements

North America is in the forefront for adopting 5G NR mmWave technologies, with considerable investments in mmWave spectrum and multiple deployments in macro, outdoor, and indoor environments (e.g., stadiums, airports). Taking advantage of the higher capacity and data rates for mmWave, these deployments enabled multiple new use cases (e.g., Super Bowl stadium coverage). To maintain this North American leadership, 6G research needs to focus on advancing and streamlining the mmWave technology by making it simpler to implement, easier to deploy, easier to integrate, able to co-exist with current and future technologies, and helping networks and UEs and other nodes have better performance (e.g., better mobility, better power efficiency, improved robustness against phase noise, and better coverage). Research needs to be aimed at enhancing existing 5G technologies, in addition to introducing new technologies to enable those more advanced and streamlined systems. Specific research may be focused on reducing the beam management latency and overhead, ensuring seamless mobility across nodes, beam correspondence, topology enhancements for densifying network, power-efficient RFFE, and beamforming architecture, design of reference signals that cater to power efficient architecture, design of power-efficient waveform and modulation schemes, reusing the design across different bands, techniques to overcome link robustness (e.g., beam diversity), positioning/sensing/ranging applications, interference management procedures, Uplink (UL) coverage enhancements, power savings and efficiency for network and UE, and sidelink operation enhancements.

3.1.4 Advanced MIMO Technologies

For 6G systems, MIMO technology is expected to build upon and extend the 5G MIMO framework to provide significant enhancements to overall system performance and user experience. The NR wireless standard for 5G supports a comprehensive framework for enabling massive MIMO operation in a wide variety of use cases and deployment scenarios. The 5G MIMO framework supports the use of large-scale antenna arrays with arbitrary array configurations. It also supports digital, analog, and hybrid architectures for both FDD and TDD deployments. The two main reasons for supporting massive MIMO are to enhance coverage performance via high-gain adaptive beamforming and to enhance spectral efficiency through high-order spatial multiplexing.

For 6G systems, it is anticipated that the technology for massive MIMO will be extended into several areas:

- > Enhancements aimed at sub-6 GHz bands.
- > General enhancements to the important components that enable efficient and effective massive MIMO operation in the existing 5G spectrum bands, as well as in the new upper-mid bands (7 GHz-24 GHz).
- > Enhancements aimed at supporting massively distributed MIMO.
- > Various new technologies that have the potential to provide further improvements to system performance (e.g., RIS).

3.1.4.1 Low-Frequency Band Enhancement

This paper explores massive MIMO technologies as a key enabler for widespread adoption of 6G systems, across the whole 6G spectrum. Advanced massive MIMO techniques, including distributed massive MIMO solutions, will be adopted, depending on the characteristics of each frequency band from sub-1 GHz to sub-THz bands, as shown in Figure 3.1.4.1, to enhance 6G performance and user experience.

Realizing massive MIMO gains in low-frequency bands is expected to have a major impact on widespread coverage and overall cost efficiency and energy efficiency of 6G systems.

Low-frequency bands, particularly sub-1 GHz bands in North America, define the baseline coverage of cellular networks. Unlike the higher frequency bands that 6G is expected to expand into, low-frequency bands have the advantage of exhibiting low propagation and penetration loss. These bands can, however, quickly become a bottleneck because they are expected to cover a large number of users with a relatively limited amount of bandwidth availability. It is thus crucial for 6G to work on candidate technologies to improve the spectral efficiency of low-frequency bands.

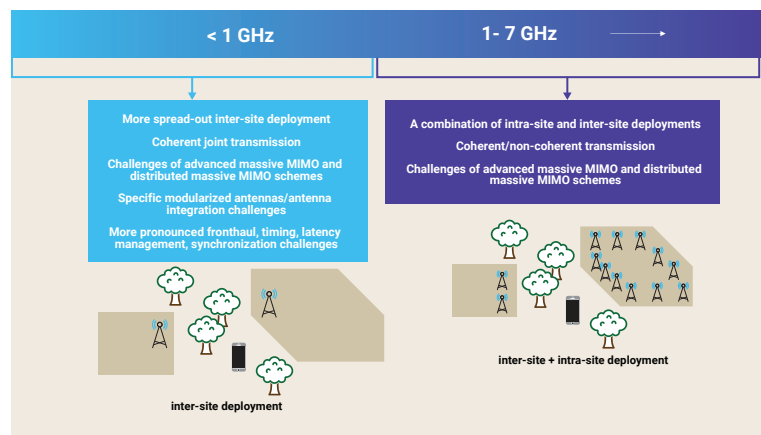

Figure 3.1.4.1: Challenges and Expectations of Advanced Massive MIMO in Low-Frequency Bands

	<1GHz	3GHz	4GHz	5GHz	6GHz	24-30GHz	37-50GHz	64-71GHz	>95GHz	
USA	600MHz (2x35MHz)	900MHz (2x3MHz) 2.5/2.6GHz (B41/n41)	3.1-3.45GHz 3.45-3.55GHz 3.55-3.7GHz	3.7-3.98GHz	4.94-4.99GHz	5.9-7.1GHz	24.25-24.45GHz 24.75-25.25GHz 27.5-28.35GHz	37-37.6GHz 37.6-40GHz 47.2-48.2GHz	57-64GHz 64-71GHz	>95GHz
Canada	600MHz (2x35MHz)	3.475-3.65GHz	3.65-4.0GHz			26.5-27.5GHz 27.5-28.35GHz	37-37.6GHz 37.6-40GHz	57-64GHz 64-71GHz		
EU	700MHz (2x30 MHz)	3.4-3.8GHz	3.4-3.8GHz		5.9-6.4GHz	24.5-27.5GHz		57-66GHz		
UK	700MHz (2x30 MHz)	3.4-3.8GHz				26GHz		57-66GHz		
Germany	700MHz (2x30 MHz)	3.4-3.8GHz				26GHz		57-66GHz		
France	700MHz (2x30 MHz)	3.46-3.8GHz				26GHz		57-66GHz		
Italy	700MHz (2x30 MHz)	3.6-3.8GHz				26.5-27.5GHz		57-66GHz		
China	700MHz	2.5/2.6GHz (B41/n41)	3.3-3.6GHz	4.8-5GHz		24.75-27.5GHz	40.5-43.5GHz			
Korea	700/800MHz	2.3-2.39GHz	3.4-3.42GHz 3.42-3.7GHz 3.7-4.0GHz		5.9-7.1GHz	25.7-26.5GHz 26.5-28.9GHz 28.9-29.5GHz	37GHz	57-66GHz		
Japan			3.6-4.1GHz	4.5-4.9GHz		26.6-27GHz 27-29.5GHz	39-43.5GHz	57-66GHz		
India	700MHz		3.3-3.6GHz			24.25-27.5GHz 27.5-29.5GHz	37-43.5GHz			
Australia			3.4-3.7GHz			24.25-29.5GHz	39GHz	57-66GHz		

Figure 3.1.4. Potential New 6G Coverage Frequency

One of the main practical limitations for massive MIMO in sub-1 GHz is the form factor in a traditional BS deployment. The limits on the amount of antennas that can be deployed in a conventional BS location at low-frequency bands, coupled with the need to considerably improve coverage and capacity, mandate exploring new, even unconventional, massively distributed antenna architectures. Sub-1 GHz enhancements will further need to leverage new transmission and channel state acquisition frameworks to provide orders of magnitude improvements as compared to wireless networks offerings that are currently deployed or under development.

Realizing massive MIMO gains in low-frequency bands is expected to have a major impact on widespread coverage and on overall cost efficiency and energy efficiency of 6G systems. The latter two are key pillars for 6G in North America. Various challenges need to be overcome, however, to enable the full potential of massive MIMO in low-frequency bands, as illustrated in Figure 3.1.4.1.

- > The form factor limitations present at traditional towers or BS locations.
- > The need and subsequently feasibility of non-uniform/non-traditional deployment antenna arrays.
- > The challenges on acquisition of channel characteristics using massively distributed antennas.
- > The hard-to-achieve synchronization to coherently combine signals from different antenna arrays/ antenna panels/BS locations.
- > The need for a scalable channel state acquisition framework that considers the distributed antenna architecture and feedback overhead.

Several research areas are subsequently underway to overcome these challenges. These include:

- > Studying the feasibility of massive MIMO in low-frequency bands in the 6G timeframe, including a survey on latest proof-of-concept activities.
- > Evaluating new concepts for deploying antennas in low-frequency bands to increase antenna integration (e.g., modularized antennas).
- > Investigating the need for new channel modeling considerations for ultra-dense distributed antenna arrays.
- > Exploring a new reference signal design framework aimed at improving channel state acquisition without increasing the overhead.
- > Enhancing channel acquisition frameworks aimed at, for example, addressing computational complexity and feedback overhead.

- > Developing algorithms to synchronize the network infrastructure for, as an example, coherent joint transmission from multiple distributed antennas.
- > Investigating advanced cooperative techniques considering practical and scalable distributed Radio Access Network (RAN) architectures.

North America is particularly motivated and equipped to carry key advancements in massive MIMO that benefit sub-1 GHz, an effort driven by operators' needs and major stakeholders' capabilities. Research is already underway to demonstrate the feasibility and effectiveness of modular antenna deployments. Cutting-edge research and development is expected to carry on in the 6G timeframe to address massive MIMO advancement opportunities in sub-1 GHz.

3.1.4.2 Advanced Massive MIMO

Massive MIMO technology is one of the major keys to unlocking 5G user experiences. The primary benefits of massive MIMO to the network and end users can be summed up as:

- > Increased network capacity.
- > Improved coverage.
- > Higher spectral efficiency and data rates.
- > A better user experience.

Advanced massive MIMO technology (also referred to as Gigantic MIMO here) promises to raise 6G's potential to a new level and is expected to be a key enabler of 6G's extremely fast data rates and wide coverage. In addition to the typical 5G spectrum – e.g., low bands (below 1 GHz), mid bands (1 GHz-7 GHz), and mmWave bands (24 GHz-100GHz) – 6G may expand to upper mid bands (7 GHz-24 GHz), where wider bandwidth is available with much lower propagation loss than in higher bands. 6G is poised to further expand to sub-THz bands (100 GHz-300 GHz) with severe path loss that necessitates high-gain narrow beams via ultra-massive MIMO antennas to be able to realize the Tbps throughput and sub-ms low-latency requirements. Antennas become smaller as the frequency bands move closer to THz bands. These new bands allow packing an extremely large number of antennas into the same or comparable form factor as in low bands.

The upper mid bands may offer a capacity-coverage tradeoff suitable for wide-area deployments and provide new opportunities for 6G technologies. As shown in Figure 3.1.4.2, the shorter wavelength at upper mid-bands allows for packing severalfold more antennas within the same aperture size as in sub-7GHz bands.

Advanced massive MIMO at upper mid-bands could provide coverage and reliability improvements beyond what is possible in 5G for operating bands in both sub-6GHz and mmWave.

The additional antennas at both the transmitter and receiver can effectively compensate for the attenuation due to the increased frequency and increase the chances for higher rank transmission in favorable propagation conditions. Together with the availability of GHz of bandwidth, lower phase noise, and higher PA efficiency, advanced massive MIMO at upper mid-bands could provide the best of mmWave in terms of data rate and the best of sub-7 GHz in terms of coverage while enabling high timing/angular resolution for sensing and positioning.

- > Improving the performance-complexity-power trade-off.
- > Energy-efficient design for increased number of antennas, etc.

Additional research areas needing further study are:

- > Channel modeling for both near and far-field links with extremely large antenna arrays.
- > Techniques for enabling wide coverage and high capacity with extremely large antenna arrays and with reliable coverage of synchronization and broadcast channels.
- > Techniques for improving robustness against UE movement.

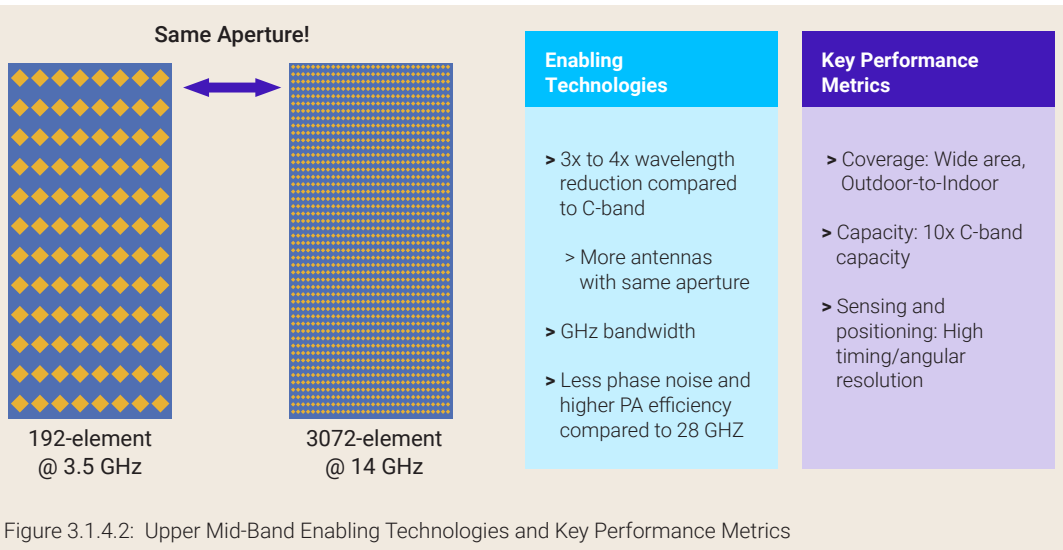

Figure 3.1.4.2: Upper Mid-Band Enabling Technologies and Key Performance Metrics

In general, advanced massive MIMO exhibits challenges for implementation across all considered frequencies in 6G. North America currently has significant capabilities in many key technology areas in 5G in both low-band and high-band applications. To maintain such a strong position in the 6G era, North America needs to keep investing in cutting-edge research to address the main challenges. These include beam management to handle mobility with much narrower beam, much shorter times for beam switching, beam tracking, channel state acquisition, hardware impairments in cost-effective implementation, and energy efficiency/power consumption for very large number of antennas.

To address these challenges and unleash the potential of such advanced massive MIMO, several topics for further study are:

- > Techniques for serving both near-field UEs and far-field UEs.
- > Scalable beamforming architecture and Channel State Information (CSI) acquisition.
- > Antenna arrays with non-uniform antenna spacing.
- > Techniques that are robust in moderate and/or high-speed scenarios.

- > CSI acquisition with low or moderate reference signal overhead, along with interference estimation at network and UE while addressing computational complexity and feedback overhead.
- > Advanced beam management frameworks exploiting advanced beamforming architectures.
- > Advanced UE beamforming options.
- > Co-existence with other deployments in the same band, including techniques to mitigate interference.
- > Techniques for power/energy savings for network and UE.
- > Smart beam management (e.g., using AI/ML algorithms).

Massively distributed MIMO in 6G will leverage coordinated transmission and interference management techniques to achieve system coverage and reliability improvements for both sub-6GHz and mmWave bands.

3.1.4.3 Massively Distributed MIMO

Massively distributed MIMO refers to the systems where a very large number of service antennas located at a large number of locations serve multiple users distributed over a wide area and on the same time-frequency resources. The 5G baseline for multi-Transmission Reception Point (TRP) operation is non-coherent joint transmission involving two TRPs. For 6G, the goal is to extend that baseline into massively distributed MIMO that is enabled through low-cost densification and scalable methodologies for cooperation and coordination between a very large number of cells or multi-TRPs. Massively distributed MIMO promises to provide system coverage and reliability improvements beyond what is realizable in 5G for operating bands in both sub-6GHz and mmWave. For massively dense user populations, coordinated transmission and interference management promise to provide higher capacities than can be achieved in 5G. For mmWave deployments, low-cost densification will be important for mitigating the difficult propagation challenges due to increased path loss, high penetration losses, and high blockage losses.

North America currently has significant capabilities in many key technology areas in 5G in both low-band and high-band applications. To maintain a strong position in the 6G era, North America needs to keep investing in cutting-edge research in massively distributed MIMO to address two key opportunities for 6G.

The first opportunity is to provide a more comprehensive utilization of mmWave spectrum where large system bandwidths are available, but the relatively high site density limits the benefits of such spectrum. Similar opportunities exist for other bands above 6 GHz, as well (e.g., 7-24 GHz and sub-THz and THz bands).

The second opportunity is to provide significantly improved performance in sub-6 GHz deployments having high user densities and high user traffic levels, where coordinated transmission and interference management techniques can be particularly beneficial. Massively distributed MIMO is one of the key enablers of sub-THz and THz communications that can support highly directional beams to improve received signal strength whilst providing seamless mobility to enhance the limited coverage under high frequencies. Making use of massively distributed MIMO, enhanced joint transmission techniques, and new reference signals and CSI frameworks will also give 6G the flexibility and scalability to have a unified solution for all potential spectrum bands.

The primary challenge for massively distributed MIMO will be to develop cost-effective technologies for enabling advanced multi-TRP operation. These include advanced transmission schemes, synchronization schemes, channel state acquisition and feedback, coordination schemes, interference management and suppression, and mobility enhancements for seamless mobility. Realizing low-cost/cost-effective densification will be another major challenge. Research areas will include:

- > Techniques and technologies to enable efficient and low-cost densification, including techniques for lowering front-haul bandwidth requirements for both symmetric and asymmetric UL and Downlink (DL) densification.
- > Enhanced multi-TRP operation enabled by CSI Reference Signal (CSI-RS), Sounding Reference Signal (SRS), and/or UL measurements, including advanced pre-coding schemes and schemes requiring synchronization to coherently combine and/or transmit signals from multiple distributed antennas in different locations.
- > Enhanced multi-TRP operation for data and control channels and applicable to both DL and UL channels aiming at enhanced reliability and lower latency.
- > Enhancements to CSI and SRS frameworks for improved CSI acquisition in massively distributed MIMO, taking into account distributed architecture and feedback overhead.
- > Technologies for network infrastructure synchronization and calibration to enable enhanced joint transmission.
- > Algorithm design for distributed and scalable signal processing.
- > Advanced cooperative techniques including (coherent and non-coherent) joint transmission and interference management (e.g., coordination, cancellation, and suppression).
- > Enabling support of high-velocity UEs/High Speed Train (HST) with massively distributed MIMO.
- > Supporting UEs capable of transmitting/receiving higher number of spatial layers (e.g., more antennas and transceivers at low-frequency bands, more transceivers and panel arrays at high-frequency bands).
- > An initial access framework to enable efficient on-demand densification via massively distributed MIMO.
- > Mobility enhancements to enable seamless mobility in massively distributed MIMO.

- > Practical and scalable user-centric (or cell-free) architectures for massively distributed MIMO and advanced massive MIMO.

Massively Distributed MIMO

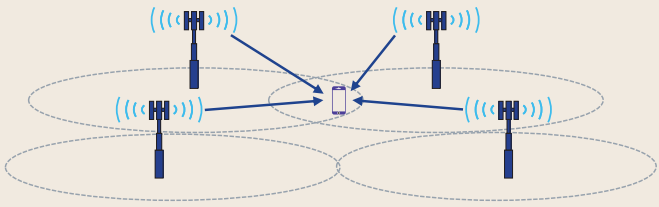

Benefits

- > Coordinated transmission and interference management beneficial with high user densities/traffic levels
- > Blockage mitigation and coverage reliability improvements to enable comprehensive use of mmWave spectrum
- > Key Enabler for mmWave, Sub-THz and THz operation

Challenges:

- > CSI acquisition, coordination schemes, interference management/suppression, mobility enhancements, synchronization schemes for advanced coherent transmission

Figure 3.1.4.3: Benefits and Challenges of Massively Distributed MIMO

3.1.4.4 Reconfigurable Intelligent Surface (RIS)

A RIS is a large and thin meta-surface of metallic and dielectric material comprised of an array of passive sub-wavelength scattering elements called “unit cells” with specially designed physical structures. The characteristics of the unit cells can be controlled dynamically in a software-defined manner to tune the incident RF signals through reflection, refraction, focusing, collimation, modulation, and any combination of these.

A wireless mobile communication network traditionally adapts transmission schemes of the transceiver endpoints to mitigate or leverage the dynamic multipath propagation environment for optimized performance. RIS offers a potential solution to achieve a software configurable smart radio environment. Due to the mostly passive nature of

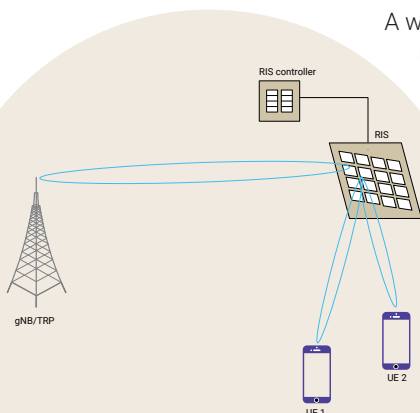

Figure 3.1.4.4: Reconfigurable Intelligent Surface

the RIS, it only recycles existing RF signals rather than actively generating RF signals. Therefore, RIS can be considered non-invasive to the radio environment and can potentially be deployed on a large scale if its cost can be made sufficiently low compared to other deployment solutions that require full RF chains.

RIS offers a potential solution to achieve a software-configurable smart radio environment.

Deploying RIS within the wireless network promises to bring new or enhanced capabilities to 6G as shown in Table 3.1.4.4.

Area	New or Enhanced Capability
Coverage	Mitigate blockage (especially for mmWave) and provide ultra-reliable coverage by reflecting RF signals toward the coverage holes.
MIMO Spectral Efficiency	Enhance system spectral efficiency non-invasively by providing additional degrees of freedom in the radio environment and even mitigating interference.
Integrated Sensing and Communication	Platform for integrating new sensing capabilities and providing communication for the sensors.
Location Service	Aid location service by providing extra controllable multipaths/anchor points.
Wireless Power Transfer	Enhance efficiency of wireless power transfer systems.
Physical Security	Provide physical security by selectively blocking signals (e.g., between indoors and outdoors).

Table 3.1.4.4: RIS Applicable Areas and New/Enhanced Capability

Various challenges exist in bringing to reality the opportunities promised by RIS technology. The system benefit and new capabilities that RIS could potentially bring make sense at the conceptual level. However, their effectiveness in real-world cellular scenarios remains to be clearly shown. The current understanding is that a RIS requires a rather large number of controllable elements to provide significant performance gains. A major challenge is to find an effective configuration of the large number of controllable elements for each unique scenario in a timely manner with low control overhead. It may require fast and accurate estimation of the channels between the RIS and the communication end points, coordination between multiple BSs, and additional sensing capabilities at the RIS. This is very difficult with a purely passive design. Adding receivers to RIS would help, but it comes at an additional cost that must be significantly lower than that of active TRPs or repeaters to make economic sense. Not only hardware cost, but also deployment and operational cost, such as ease of site acquisition, low visual impact, etc., all play an important role in enabling large-scale deployments for RIS.

RIS has been a very active research area for academia, with many survey papers summarizing recent progress, such as [12]. Much innovation is still needed to advance the technology toward practical applications. North America can leverage its strength in cross-discipline innovation to gain leadership in this nascent area. Investment in supporting fundamental academic research of EM structures with novel properties, and joint innovation between academia and industry in the development of techniques such as AI/ML to tackle the sensing and control challenges, is needed.

3.1.5 Holographic Beamforming and Orbital Angular Momentum (OAM)

As the demand for higher data rates continues to push the envelope of spectral efficiency, advanced techniques for MIMO and multiple access are vital considerations for 6G. Beamforming methods that have been foundational to 5G deployments should also receive considerations for further advancements in 6G. A clear example of this is holographic beamforming, which uses optical holography principles with passively steered antennas to transform reference waves into the desired beam shape and direction [13]. Beyond advances such as holographic beamforming, 6G faces the growing challenge to encode even more information in wireless signals. Existing data multiplexing techniques for communications have included time, frequency, amplitude, phase, polarization, and spatial diversity. The race to keep up with the demand for higher data rates has helped to spur further research into promising possibilities, such as the use of OAM for wireless communications. From the discovery in 1992 that light beams with helical phase fronts can carry OAM, subsequent research has further validated that OAM can be applied more broadly to RF transmissions [14]. OAM is an electromagnetic wave property that describes the helical phase pattern of a wavefront. In short, OAM tells us the degree of “twist” of a beam. The amount of phase front “twisting” indicates the OAM mode (called l), and beams with different OAM modes, are spatially orthogonal.

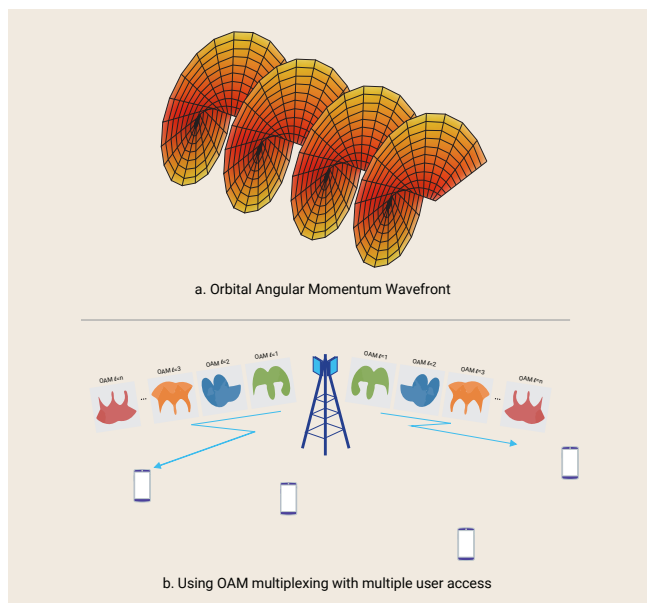

Figure 3.1.5: Orbital Angular Momentum

The use of multiplexing based on orbital angular momentum raises the possibility of even greater system capability and spectral efficiency over what traditional techniques alone can achieve.

A key opportunity with a holographic beamforming architecture is to significantly reduce the antenna systems’ cost, size, weight, and power. The use of OAM raises the possibilities of even greater system capacity, higher spectral efficiency, and more users accessing the spectrum compared to what is achievable with traditional techniques alone, due to an infinite number of OAM modes. Furthermore, OAM could be leveraged for anti-jamming improvements either as an alternative to, or in combination with, frequency-hopping techniques [15].

Several important challenges must also be overcome for OAM to serve as an integral part of 6G communications. First, long distance transmissions are challenged by greater errors with beam divergence due to the nature of the OAM wavefront; namely, the OAM wavefront is vorticose hollow (e.g., ring/doughnut shaped when facing it). Therefore, the beam “expands” with greater losses in the far field. As a result, beam convergence is required to compensate and decode the received signal at relatively long distances. Fortunately, the need for convergence decreases at higher frequencies since the divergence of OAM beams is also reduced at higher frequencies. The effects of scattering and reflections in the environment need to be carefully considered because unlike with optical fibers, in which OAM transmission was first demonstrated, in free space wireless scattering mixes the OAM modes. The achievable performance in general indoor or outdoor environments has yet to be quantified. Finally, using OAM beams may require significant revision of the digital signal processing path of a radio in order to synthesize and detect the beams in an energy efficient manner. Hardware accelerators for conventional wireless have been highly optimized; research into new computational structures may be needed for OAM beams.

Advances such as holographic beamforming warrant prioritization of research and investments in North America for leadership in 6G. Holographic beamforming can yield notably lower cost, size, weight, and power consumption of antenna systems, leading to nimbler and flexible designs that can support the varied deployment environments and local regulations found across the region. In turn, better solutions can be designed to leverage the large but underutilized mmWave spectrum investments in North America. Future research should also investigate the potential benefits and suitability of OAM in conjunction with spectrum sharing and management techniques, such as improving interference mitigation capabilities and new anti-jamming methods.

3.1.6 Advanced Duplexing Technology

5G deployments are based on separating UL and DL transmissions either on paired spectrum using dedicated UL and DL channels separated in the frequency domain (e.g., FDD), or on unpaired spectrum that is shared between UL and DL channels separated in the time domain, e.g., TDD. 5G networks

have some capabilities to support the semi-static or dynamic adaptation of the partitioning between UL and DL resources at the BS. However, the extent to which these capabilities can be utilized is limited by the ability to mitigate cross-link and self-interference from neighboring BSs or the same BS, respectively. The introduction of 6G radio access networks presents a new opportunity to go beyond TDD and FDD operation modes. This would be done via full-duplex operation that leverages the benefits of both TDD and FDD deployments and is supported at both the BS and the user device across cellular/sidelink, and Terrestrial Networks (TN)/NTNs communication scenarios.

From a 6G network perspective, full-duplex operation improves system capacity, increases UL and DL data rates, and reduces latency over-the-air interface. These are achieved through simultaneous transmission and reception using the fully or partially overlapping time and frequency resources at both the BS and user device. From a user device perspective, full-duplex opportunities include the ability to increase efficiency by reducing or removing guard bands in low- and mid-band spectrum, which has conventionally required FDD operation. In addition, the use of adaptive analog/digital beamforming across one or multiple antenna panels can increase the feasibility and performance of full-duplex operation in higher frequency bands thanks to improved spatial and beam isolation. In addition to operating in the frequency ranges currently supported by 5G networks, adopting full-duplexing schemes in new spectrum for 6G in even higher frequency ranges (e.g., upper-mmWave/sub-THz) can boost system performance and facilitate key 6G use cases such as ultra-precise localization and sensing.

One critical issue across all scenarios is the need for cross-link and self-interference characterization, handling, and mitigation. The extent of the challenges and potential solutions may differ based on transmit power (e.g., macro or micro BSs), device form factor (e.g., handheld UE, Customer Premises Equipment (CPE), UAV, satellites), number of Tx/Rx chains for interference cancellation, and the use of overlapping vs. non-overlapping UL/DL transmissions as some examples. Furthermore, full-duplex scheduling algorithms must counter the challenges of inter-device in-band cross-interference in dense and/or mobile UE environments. Additionally, the need for interference mitigation may extend beyond a single 6G deployment, but it could also extend to co-channel or adjacent channel deployments belonging to different operators and may further include legacy device impact considerations.

From a North American technology leadership perspective, there are multiple research areas that are key to ensuring that advanced duplexing schemes such as full-duplex operation can be practically applied to 6G use cases and deployment scenarios for enhanced digital world experiences. These include defining channel models and performance evaluation methodologies for various interference scenarios and frequency bands that take into account the impact of both near-field and far-field (e.g., reflections) effects as shown in Figure 3.1.6. Another area is the development of technology enablers including:

- > Advancements in RF, analog, antenna, and interconnect hardware to improve spatial and

frequency domain isolation and interference suppression.

- > Self and cross-link interference estimation, cancellation, and interference avoidance/mitigation techniques enabled by the air interface.
- > Techniques to mitigate the impact of transceiver non-idealities.
- > Advanced duplexing schemes should be considered in the protocol layer and network architecture design to natively leverage the capabilities on a link and system basis.

>

Figure 3.1.6: Overview of a Full-Duplex Cellular Network Deployment Scenario

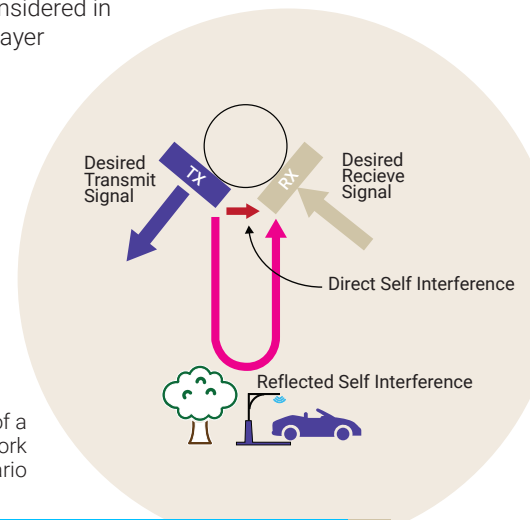

The introduction of 6G radio access networks presents a new opportunity to go beyond TDD and FDD operation modes. This would be done via full-duplex operation that leverages the benefits of both TDD and FDD deployments. It would be supported at both the BS and the user device across cellular/sidelink and TN/NTN communication scenarios.

3.1.7 Seamless Mobility

Today's wireless devices are fully dependent upon the network for any cellular operation, including mobility control. These cellular mobility operations consist of multiple procedures including handovers, cell selection, cell re-selection, beam management, and CSI reporting. These operations involve extensive signaling information exchanges between the network and device, causing delays and overhead that make the entire ecosystem less robust and less power efficient. It is a major challenge for networks and devices to maintain reliable connections and high throughput during device mobility scenarios. Making use of high-frequency spectrum like 5G mmWave or future THz deployments results in reduced range of communication and the use of narrow beams, further increasing the challenges for networks and devices during mobility. Mobility failures such as Radio Link Failures and handover service

interruptions also heavily impact the user experience. By introducing AI/ML-based enhancements and simplified, minimized control signaling, cellular operations could be made more power and performance efficient.

6G device users can benefit from more reliable communication in mobility scenarios enabling interruption-free and robust data transmission and reception across radio technologies.

6G device users can benefit from more reliable communication in mobility scenarios enabling interruption-free and robust data transmission and reception across radio technologies. This also includes optimized interworking with other entities of the 6G ecosystem (e.g., sidelink and TN/NTN interoperation). Wireless networks will benefit from improved KPIs in terms of reduced handover failure rates, reduced radio link failure rates, and reduced signaling and processing overhead.

introduced, 6G waveform and multiple access technologies are expected to continue to evolve based on 5G waveform and multiple access schemes to improve spectrum and power efficiency, provide more robust coverage, supplement adjacent 6G technologies such as advanced MIMO (e.g., advanced beam/CSI acquisition and tracking) (see Section 3.1.4), and ultra-low resolution data conversion technologies (see Section 3.2.1). Channel coding and modulation design will also continue to advance to scale to extremely high throughput (together with bandwidth and MIMO order scaling), link reliability, and low latency, as well as meeting other requirements for specific use cases such as massive Machine Type Communication (MTC), which needs to support high connection density and high user density.

In addition to established use cases, the 6G waveform, multiple access, coding, and modulation design are expected to enable new use cases and new verticals such as joint communication, positioning, sensing, and Physical Layer

(PHY) security, all of which have attracted research interest in both academy and industry. Meanwhile, cross-disciplinary research areas and technologies such as AI/ML have emerged as new tools for wireless communication physical layer design. One key question is how to leverage powerful AI/ML technologies, tools, and data-driven design methodology in crafting fundamental building blocks for 6G systems.

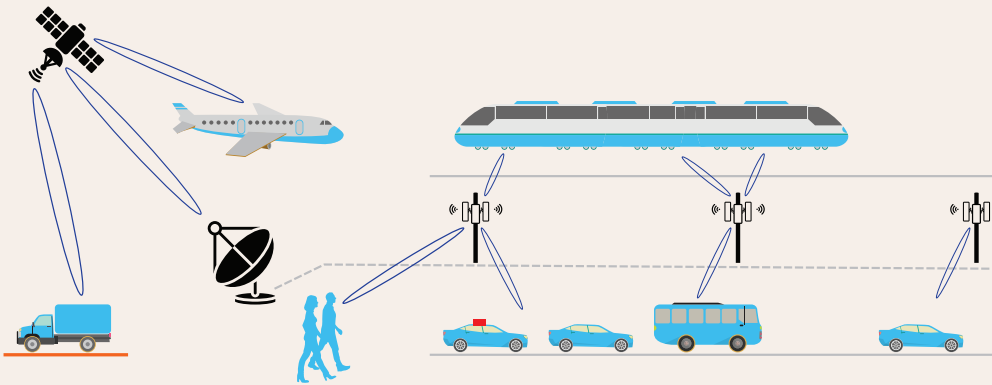

Figure 3.1.7: Seamless Mobility

The target is to research and develop robust methods for interruption-free handover between cells of same technology and across technologies while simplifying and minimizing the amount of control signaling, signaling delays, procedure delays, and processing efforts. This goal includes optimization of device power consumption under mobility scenarios and for mobility-related procedures. For applicable use cases and scenarios, local and combined coordinated AI/ML could be considered to achieve the targets.

For North America to obtain 6G leadership, investment is required to research novel and superior solutions for seamless mobility procedures to meet KPI targets across all 6G use cases. The major aspect is to enable reliable, interruption-free, and robust data transmission and reception across various radio technologies.

3.1.8 Waveform, Coding, Modulation, and Multiple Access Schemes

Waveform, coding, modulation, and multiple access are fundamental building blocks of cellular systems in every generation. As more and more frequency bands are

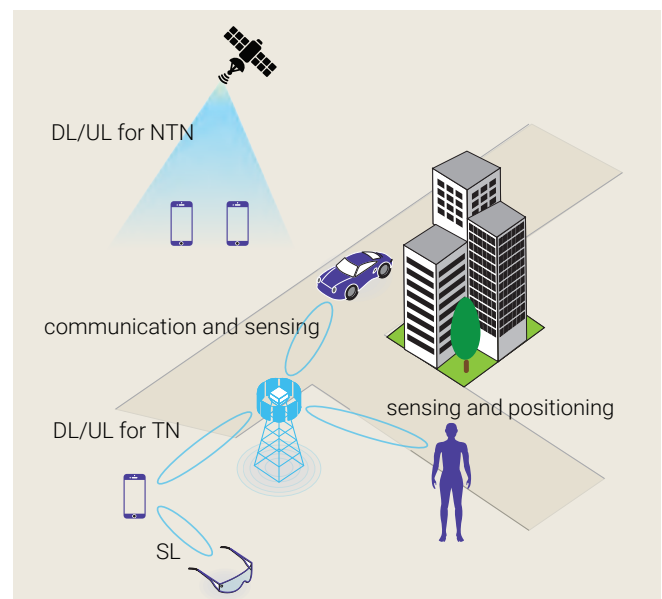

Figure 3.1.8: Waveform, Coding, Modulation, Multiple Access 6G Use Case Scenarios

As the industry evolves toward 6G, there are new technology and business opportunities, as well as design challenges to meet 6G requirements. First, the unified 6G design —

comprising waveform, numerology, coding, modulation, and multiple access — needs to support key 6G KPIs such as higher spectral and power efficiency, extended link budget, enhanced reliability with low latency, as well as robust high-velocity performance across a large range of carrier frequencies, scalable with channel bandwidth, MIMO order, and flexible enough to serve different verticals across DL/UL/sidelink, TNs and NTNS, communication and non-communication (e.g., sensing, positioning, PHY security) use cases and so forth as illustrated in Figure 3.1.8. Waveform, modulation, coding, and multiple access design also play crucial roles in reducing the cost and complexity of RF and baseband hardware while maintaining high performance, especially as 6G systems venture into ever higher dimensionalities in time, frequency, space, and use cases.

The waveform and multiple access design are expected to organically co-evolve with, and fit into, other new advanced RAN technologies of 6G systems as outlined in this report. They will substantially improve, among other aspects, 6G mobile broadband performance and enable 6G massive MTC intelligent connectivity while achieving harmonic coexistence with other RATs (e.g., 5G, Narrow Band-IoT (NB-IoT)).

Research in 6G waveform, coding, modulation, and multiple access domains is expected to facilitate high data rate scaling, further coverage improvement, latency reduction, energy efficiency, and cost and complexity reduction. It is also expected to enable new use cases such as joint communication and sensing, positioning, PHY security, etc.

North America has a long history of innovation in physical layer fundamental research. To continue driving the wireless research in 6G era, substantial investment needs to be made in classic communication use cases to further scale up data rate, spectrum efficiency, etc., while maintaining a sustainable processing complexity. Substantial investment also is necessary in new inter-disciplinary areas of communication and other emerging fields. Further strengthening the collaboration between academia and industry is also critically important to the success of North America's 6G leadership. This close collaboration will feed academia with fresh and meaningful new research topics, as well as expedite the adoption and commercialization of innovative ideas from academia.

3.2 Radio Technologies for Green Communications

It is well known that global warming must not exceed 1.5 degrees Celsius to avoid climate catastrophe [1]. Nevertheless, green communications are not solely about global temperature

increase and GHG emissions. While renewable energy sources and significantly reduced energy consumption are paramount, green networks also address biodiversity loss, toxic waste management, air pollution, and sustainable land usage, water consumption, and material sourcing. Green networks comprising data centers, the Core, the RAN, and UEs are thus truly sustainable only when their manufacturing, supply chain, and end of lifecycle are also green and sustainable, for hardware and software components alike. This report is testament to that vision and goal, covering relevant technologies (e.g., for components, compute and storage infrastructure, protocols and radios, operation, administration, and maintenance, and overall network and system architecture). Among these, this section focuses on radio technologies and protocols for the RAN and devices.

In addition to 6G systems being sustainable, green communications offer two more crucial benefits: enablement of other industries and sectors beyond Information and Communications Technology (ICT) to also be more sustainable, and increased affordability due to reduced energy consumption. The latter, in addition to the many expected societal and economic benefits, can also enable other 6G technologies. One example is the new waveforms that are designed to significantly reduce power consumption in devices and enable near-zero energy communications. These waveforms may reduce complexity and, ideally, in turn make ultra-massive, possibly distributed MIMO networks a practical reality. This is just one potential example of the aforementioned catalytic, secondary effects of green communications on other technologies and applications. In fact, to continue this example, such complexity reductions primarily geared toward energy reduction could subsequently also make new frequency regimes a practical reality. These examples thus underline the fundamental role green communications technologies play in all aspects of a 6G system beyond just sustainability, from improved affordability and its societal and economic benefits to new use cases, applications, and spectrum regimes, and many more.

3.2.1 Green Networks and Ultra-Low-Resolution Communications Systems

The RAN accounts for over half of the power consumption in a cellular network driven by ever-increasing dimensionalities in carriers, antennas, transmission points, and use cases that need to be serviced.

The ICT industry is projected to potentially contribute as much as 20% of the global energy consumption by 2030 [1]. Communications networks must be attentive to global priorities pertaining to climate change, especially the reduction of energy used by the ICT industry. Therefore, energy consumption is as relevant to 6G as any other aspect of a communications system. It is thus no coincidence that NGA has a Green G working group, which addresses sustainability and energy efficiency for end-to-end networks including UE, RAN, Core, and data centers. Specifically, it is the RAN that

accounts for over half of the power consumption of a cellular network, and over half of that can be attributed to PAs.

Indeed, every new generation of cellular networks has consistently succeeded in improving energy efficiency (bits/joule) over the preceding generation. However, the growth in traffic that every new generation has been accommodating works against these targeted gains. For example, network densification increases the number of transmission points, while higher carrier frequencies lend themselves to larger numbers of antennas; in the case of higher spectrum bands (e.g., mmWave and sub-THz/THz spectrum), the operating frequencies naturally trend toward wider bandwidths, resulting in worse impairment characteristics for RF electronics, along with higher sampling rates for digital processes and data converters. High clock rates demand power consumption that increases approximately with linear proportionality. Energy efficiency must thus be all-pervading in the design of 6G radio technologies, given they are the primary drivers for energy consumption through ever-increasing dimensionalities in carriers, antennas, transmission points, and use cases that they need to service.

Energy consumption in the RAN occurs from fixed overhead, constituting static overhead and dynamic consumption that follows activity related to communication and non-communication tasks.¹ 6G systems should further reduce the static and dynamic power consumption beyond the lean carrier features of 5G NR and include other Network Functions (NFs) beyond the air interface. The challenge lies in finding the trade-off between network energy efficiency and user experience. For example, what often prevents energy efficient implementations is the requirement of high resolution and linearity in state-of-the-art systems. Consequently, introducing non-linearities into the transmission chain through low-resolution data converters can reduce the power consumption of the radio while data is actively being served.

Energy efficiency in the RAN is a rather mature research area that can broadly be classified into three categories: hardware efficiency, software functionality, and energy management. The aforementioned lean carrier design of 5G NR has mostly focused on the broadcast of common signals and channels. 6G systems are expected to further improve upon that (e.g., through enhanced on-demand transmissions of these). Low-overhead reference signal designs for CSI acquisition and radio resource management are examples of successful energy reduction in 5G that 6G systems can advance. Energy efficiency in the RAN almost always centers around some kind of on/off technique or other dynamic adaptation in space (e.g., number of Tx/Rx chains), time (e.g., context preserving idle states), frequency (e.g., bandwidth adaptation incl. number of carriers), and power (e.g., power control of access points and Peak-to-Average Power Ratio (PAPR) reduction). These can leverage AI/ML-based design in 6G systems, enabled by both UE and inter-node network assistance.

On the other hand, research on low-resolution architectures with relaxed design parameters for ultra-massive fully digital

antenna arrays will have to account for the non-linear aspects of low-resolution designs and leverage the resulting non-linearity. This requires advancements in modelling, calibration, and feedback, including enhanced transmitter pre-distortion and cooperative design of transmitter and receiver signal shaping that fulfil regulatory compliance of low-resolution front-end architectures with degraded out-of-band emissions.

Advances in radio components also play a fundamental role in the energy efficiency in the RAN, particularly in the PA. Innovations within the value chain for equipment can furthermore improve the carbon footprint of RAN solutions and should incorporate the entire product lifecycle from material sourcing and mining to manufacturing, supply chain, and waste management. Lastly, sustainable water, land, and air use, and mitigation of biodiversity loss are just as important as the reduction of GHG emissions.

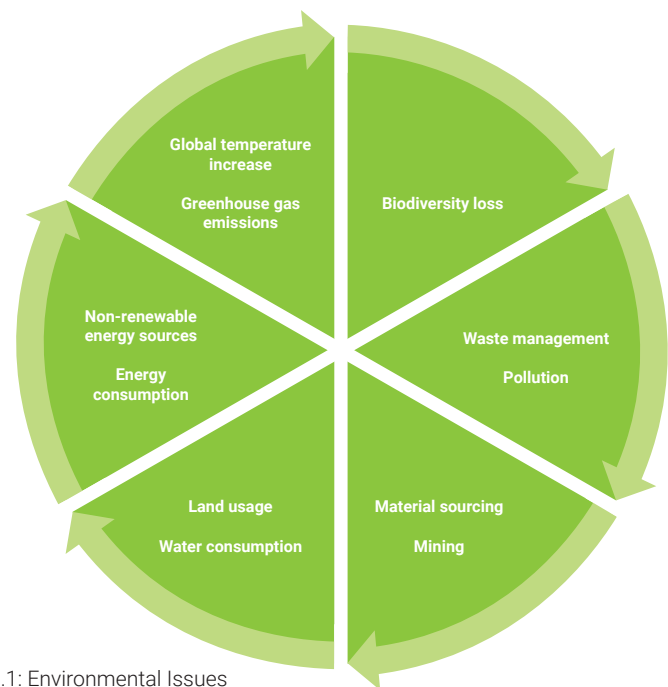

Figure 3.2.1: Environmental Issues that Need to be Considered for 6G

The aforementioned research directions are of paramount importance to North America due to their societal and economic impact, in addition, of course, to their environmental benefits and mandate. They will result in improved quality of life and health, increase food and water security, and reduce overall inequality. They will foster innovation and growth, establish circular economy principles, and provide greater infrastructure resiliency to businesses and citizens alike. A sustainable 6G system with an energy-efficient RAN can also help enable other sectors reduce their carbon footprint and be more sustainable. Last but not least, energy efficiency greatly reduces cost, making 6G systems more affordable, which creates economic and educational opportunity with the potential for further health and quality of life improvements through reduced inequality.

¹ In addition to the activity in the data and signaling stack related to maintaining connectivity, there are non-communication tasks such as computational functions associated with services, location, environmental sensing, storage caching, and AI.

3.2.2 Device Power Saving

Early adoption of device power consumption as an all-layer fundamental KPI is essential. 6G technology must enable energy-efficient device operation to deliver required performance in all highly demanding scenarios. This goal must also be achieved without compromising on network power consumption or system performance.

Handheld device power consumption is a fundamental limitation that relates to both battery capacity and thermal dissipation capability. Although improvements in battery technology may deliver higher power density in the future, thermal power limitations are unlikely to be overcome in future generations. For example, the thermal limitation in 6-inch smartphone devices forces average device power consumption to remain below the 3-5 W limit to maintain device surface temperature within safe levels.

New device form factors poised to be more prevalent in 6G (e.g., advanced telepresence, holographic communications, Internet of senses) may present even more stringent requirements than today's smartphones. There are due not only to their form factor (limited battery volume in glasses, for example) but also to the fact they will be worn as opposed to be held/carried (tighter heat dissipation requirement due to constant skin contact).

Device power consumption is driven by the combination of required performance, design characteristics, and activity patterns from all components within a device, from the antenna, transceiver, baseband, and stack all the way to the application processing, screens, sensors, and other transducers for all-sense communication. The table below contains a non-exhaustive list of anticipated challenges to reduce device power consumption.

Challenge	Possible Research Directions
10x-100x increases in peak data rates, coupled with additional latency reduction	Coding, modulation, ciphering, physical layer procedures, and user plane protocol stack design techniques, leading to substantial reductions in average processing complexity per bit delivered.
Power efficiency for mmWave and sub-THz/THz	Power-optimized analogue circuitry. Physical layer procedures with extremely low operation duty cycles during data transmission or reception inactivity.
Increasingly sophisticated RF architectures to support higher MIMO orders in upper mid-band frequencies (7-24GHz)	Highly efficient novel RF architectures and analogue components. Physical layer procedures with extremely low operation duty cycles during data transmission or reception inactivity.
D2D cooperation	Enhanced D2D protocols requiring reduced device activity cycles and low signaling overheads.
Device processing requirements to handle mobility scenarios for mmWave and sub-THz/THz	Novel approaches enabling high-performance mobility with reduced device processing demands and short activity cycles for cell search, measurements, beam tracking, radio link monitoring, and other device housekeeping tasks.

Table 3.2.2: Possible Research Directions for Device Power Saving

Early adoption of power consumption as an all-layer fundamental KPI seems essential, given that the power increase caused by anticipated device complexity is likely to be higher than any efficiency gain reduction delivered by newly available technologies. Device and network energy efficiency can be very tightly coupled, and difficult trade-offs between the two will likely emerge. 6G technology must enable energy-efficient device operation to deliver required performance in all highly demanding scenarios. This goal must also be achieved without compromising network power consumption or system performance. Proposed solutions should also fully leverage the knowledge on device activity pattern and introduce new techniques that may allow device cooperation as a means of power consumption optimization.

From a North American perspective, it is extremely important for all relevant research disciplines to become power-aware from the early inception of Next G technology. A strong focus on power efficiency can be achieved by defining and adopting relevant KPIs for both network and device, encompassing the power consumption in all their subsystems. Accurate-enough methodologies will be required during the early stages of standard definition to anticipate, model, and predict power consumption for relevant form factors, scenarios, and use cases.

3.2.3 Near-Zero Energy (NZE) Communications

6G systems are expected to scale to support 500 billion devices, primarily driven by smart factories, cities, agriculture, retail, logistics, health, wearables, vehicles, and homes. The Internet of Things (IoT) market is expected to enable USD 5.5 trillion to USD 12.6 trillion USD in value

globally by the year 2030, with 65% of this being accounted for by B2B applications [16]. Many IoT applications involve the use of low-energy sensors to monitor/measure physical quantities and perform a wide range of functions. It is important for 6G IoT technology to be adaptable to a range of use cases, which could span remote monitors requiring long-range to nearfield devices for point-of-sale security. Data requirements could range from infrequent readings (e.g., once per day) to bursts of video data. In most cases, device lifetime is an important factor as they may be deployed in hard-to-reach places.

The IoT market is expected to reach 500 billion devices by 2030, which even with a 10-year lifetime, would mean replacing approximately 1 billion batteries per week. It is essential for 6G to support operation based on harvested energy in order to achieve this scale.

Battery replacement is a significant barrier to adoption of IoT solutions at a massive scale. In many cases, the cost of replacing the battery is two orders of magnitude higher than the device cost itself, limiting the number of devices deployed.

The limitations of batteries necessitate the need for Near-Zero Energy (NZE) devices that are capable of connecting and communicating over the cellular network. These communications are expected to prioritize energy efficiency and range over reliability, latency, and throughput. A NZE device takes advantage of ultra-low-power radio circuits (e.g., nano-Watt receivers) that could be powered by energy harvested from ambient energy sources (e.g., solar power, thermal energy, wind energy, salinity gradients, kinetic energy) or from dedicated RF-based signals. NZE communication will enable a wide range of IoT use cases to operate from harvested energy alone, therefore eliminating the battery and the limited lifetime and maintenance costs. NZE devices can dramatically scale the adoption of IoT devices, allowing devices to be placed in more locations without the requirement for battery replacement.

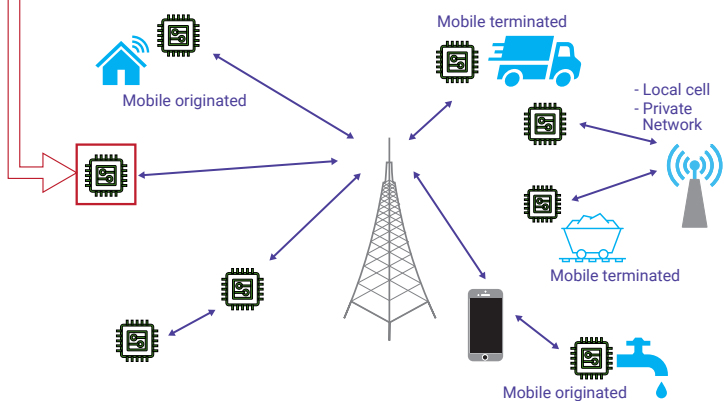
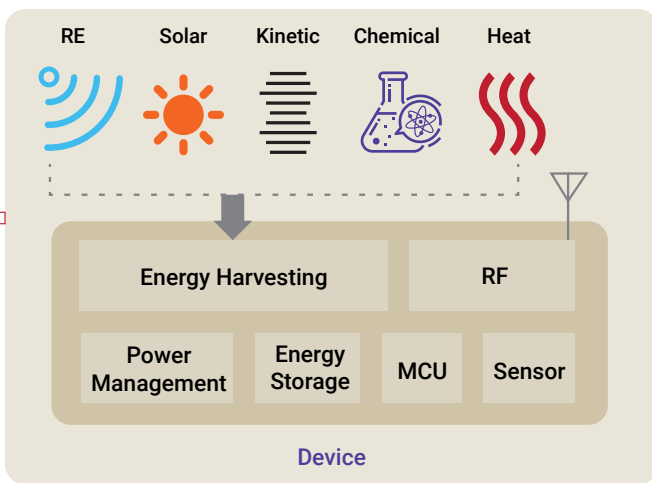

Figure 3.2.3: NZE communication will enable a wide range of IoT use cases. NZE device operating from harvested energy (upper), and network diagram showing diversity of connections (lower).

The primary challenges for NZE communications include:

- > Providing stable power from potentially intermittent sources of harvested energy, given the extremely low complexity and small form factor of NZE devices.
- > Given the limited amount of harvested energy, how to fulfill the communication requirement in typical NZE communications use cases and scenarios.
- > Support of NZE devices at a massive scale should not degrade the performance of other existing devices in the same and adjacent spectrum bands.
- > Encryption/authentication can be burdensome for computation- and power-limited devices, so protecting user privacy and system security in NZE communications is a concern that needs to be addressed.

In order to make NZE communications in 6G a reality, the following key research topics need to be further investigated. At the device level, these are:

- > Exploring new air interfaces.
- > Circuit-level solutions for energy storage.
- > Reducing the power consumption of the radio and modem to a level that can be supported by energy harvesting in a small form factor device.
- > RF-powering technology to support RF-based energy harvesting over a larger range/coverage (e.g., energy-efficient beamforming-based energy harvesting at the device).
- > Cost-effective mechanisms to deploy NZE devices for very long lifetimes (20+ years) from the perspective of both device management and physical deployment (e.g., no physical Subscriber Identity Module (SIM) cards).

Key research topics at the network and system level, including the device, involve:

- > Waveform design for the purpose of energy harvesting for NZE devices, as well as for achieving ultra-low device power consumption associated with transmission and reception of 6G connectivity.
- > Co-existence with non-NZE devices needs to be addressed.
- > Developing spectrum-sharing techniques and signaling that efficiently utilize spectrum for high

throughput devices while affording adequate spectrum and signaling for NZE devices is required.

- > Design of lightweight communication and signaling protocols (e.g., an energy aware Media Access Control (MAC) to take advantage of an always-on receiver of NZE devices, sidelink communications between NZE devices, and minimizing the synchronization and provisioning overhead).
- > Authentication, provisioning, and user privacy tailored for NZE operation.
- > Deploying NZE devices at a massive scale (e.g., 10,000 device deployments).
- > Efficient network design to support the full integration of NZE devices into the macro 6G networks, such as relay solutions for extending the range of NZE devices, to reduce the power of NZE devices.

Enabling NZE IoT devices that operate from harvested energy is of strategic importance. It enables cost-effective mechanisms to deploy NZE devices with long lifetimes (20+ years) from the perspective of both device management and physical deployment (e.g., no need for physical SIM cards). The proliferation of battery-less, maintenance-free IoT devices at a massive scale will generate significant value across a diverse set of commercial, industrial, and defense applications. This is particularly true for North America, where the cost of labor is high, and because the North American region has fallen behind Europe in the area of sustainability. Advances in 6G research in NZE will position North America to remain a leading innovator in IoT devices.

3.3 Radio Technologies for Advanced Topology and Networking

The time is ripe to consider and apply advanced topology and networking concepts to cellular RANs. Conventional RANs have primarily consisted of topologies involving BS and UEs. BSs of varying types (e.g., macro, micro, small cells) have been considered and deployed in previous generations, possibly with other network elements such as repeaters included in the mix. A few trends suggest a need to take a fundamental look at network topologies and architectures. Wireless devices have continued to enhance their capabilities in terms of compute/communications/sensing. The recent trend of massive increases in mobile device densification is expected to continue and even intensify in the future due to the proliferation of social media, consumer, enterprise, and public safety use cases such as D2D, Vehicle to Everything (V2X), IoT, Industrial IoT (IIoT), XR, etc.

Sidelink technology has continued to evolve since it was first introduced in 4G/LTE. This leads to an important question about whether devices could take on more

advanced networking and intelligent functionalities. For example, device-centric sub-networks/mesh networks could be created within a wireless network to help offload radio access capacity, enhance radio coverage, and even meet more stringent latency requirements under certain scenarios. This allows wireless devices to discover and directly connect to neighboring devices to convey local traffic or to reduce transmission energy requirements via sidelink transmissions, possibly over multiple hops. Demand for anytime-anywhere connectivity, as well as multi-radio multi-connectivity capability, justifies the need for tightly integrated NTN that offer wide-area coverage, service availability, continuity, and scalability. Enabling radio technologies such as UE cooperative communications and device-centric mesh networks opens the door to many use cases such as extreme networking (e.g., in-industrial, in-vehicle, on-body, intra-body, or in-house sub-networks), that are either standalone networks or part of larger 6G network infrastructures, operating in semi-autonomous or autonomous fashion.

3.3.1 UE Cooperative Communications

Wireless device density has increased rapidly over the years and is expected to increase even further. It is common to find wireless devices supporting several Radio Access Technologies (RATs) sometimes simultaneously in close proximity to one another. For the most part, communication between each wireless device and the wireless network occurs through a virtual point-to-point connection, largely oblivious to the presence of other nearby devices. It is well known that cooperation among wireless devices is theoretically beneficial in improving coverage and capacity. Potential use cases shall be explored where the benefits of cooperation and coordination among wireless devices can be realized, and technologies shall be developed to realize these benefits in practice. This also includes exploration of the benefits of coordination among RATs and multiple service providers. A single service provider may not be able to achieve reliable connectivity and capacity. By combining the coverage of multiple service providers at the UE and through multi-device co-ordination, data link resiliency for various applications can be achieved and communication range, reliability, and spectral efficiency can be improved.

Cooperative communications can be used to efficiently offload data/control transmission and reception to other devices, aggregate carrier in a network using multiple devices, or aggregate carrier networks at a single device or multiple devices. It enables data sharing between devices, coverage improvement via relay (single/multi-RAT), MIMO across multiple devices, and distribution of communication-related processing across devices.

6G device users can expect to benefit from more robust coverage, improved battery life, lower device cost, and better user experience.

Leveraging the high density of wireless devices and the multiplicity of RATs can result in a more resilient and overall better-performing 6G system design. 6G device users can expect to benefit from more robust coverage, improved battery life, lower device cost, and better user experience. System-level KPIs such as system capacity, throughput, Bit Error Rate (BER), call setup, call drop rate, and coverage are also expected to improve. Enlisting multiple wireless devices or multiple RATs to accomplish the tasks of data transmission and reception inherently improves the resilience of the system. Distributed processing across devices can be leveraged to reduce device costs and improve learning parameters. Benefits of coordinated communication, such as improvements in capacity, coverage, and power reduction, can also be translated into cost reductions. The dynamic nature of coordination among devices would lead to the development of an adaptable air interface that can work under several coordination/cooperation scenarios. D2D communications in unlicensed bands can be a key enabler for home networking (with smart phones/wearables) and peer-to-peer communications.

3.3.2. Non-Terrestrial Network (NTN) and Communications



Figure 3.3.2: Future NTN Network Concept in 6G

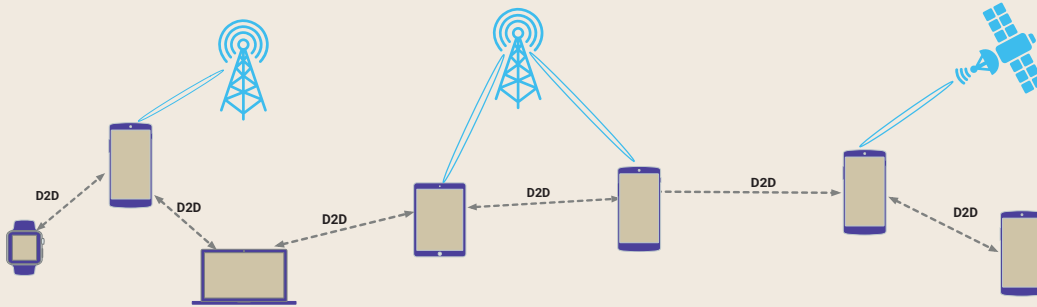

Figure 3.3.1: UE Cooperative Coordination Across Multiple Networks

NTN overlays over TN will enhance several critical aspects of communication such as service continuity, rural connectivity, and emergency response.

Based on use cases and scenarios, network topology and sub-networks deployment need to be studied. Scalable techniques for discovery and synchronizing of wireless devices, an adaptable air interface and control and transport protocols need to be developed. Efficient methods for traffic steering and dynamic routing, as well as traffic aggregation, are further important research aspects. Control protocols for radio resources management, mobility management, joint sensing, and computing resource distribution between cooperating devices need to be defined, including procedures for billing data consumption. Link adaptation and maintenance need to be studied for D2D and device-to-network connections. Research work needs to consider privacy, security, resilience, and trustworthiness across all layers of cooperation and communication.

UE cooperative communication is part of the North American view for 6G to enable device-centric communication utilizing mesh sub-networks. Network deployments benefit from more efficient operation, increasing overall capacity and coverage. Devices can benefit in terms of coverage, power efficiency, and cost.

vehicles act as a BS or relay node, with the intent of providing anytime-anywhere connectivity by offering wide-area coverage and ensuring service availability, continuity, and scalability.

NTNs are expected to play a role in 6G networks by covering many different verticals, including transport, eHealth, energy, automotive, public safety, IoT, and many others. NTNs are expected to add value to rural coverage and enhance safety and emergency response in remote locations. They also are expected to provide service continuity where it is not economically viable through TN, service ubiquity in cases of disasters that lead to temporary outage or destruction of a TN, and scalability to offload traffic from TNs.

The full potential of NTNs, including the realization of more advanced use cases likely to be realized only in the 6G timeframe. For example, the use of ultra-energy-efficient sensors on a global scale and using NTNs can provide a mechanism for unprecedented levels of data collection for critical areas such as climate change.

NTN will help achieve the goal of Digital World Experience by enabling communities currently underserved by TNs to obtain

basic voice and advanced services. This technology will also enable the goal of cost efficiency and affordability by providing a mechanism to overcome the cost burdens of providing terrestrial coverage in sparse geographies.

The key challenges to the realization of a satellite-based cellular network are large propagation delays and round-trip time, large Doppler effects, and mobility handling due to satellite movements. These have profound implications in different aspects of the system, requiring changes in both RAN and Core Network (CN), to overcome their impact in the link establishment and maintenance. NTN capability poses challenges for frequency pre-compensation and timing synchronization in relation to techniques in use for TNs. Differential delay in relation to cellular links needs to be handled effectively. Integration of Global Navigation Satellite System (GNSS) capability within the NTN satellite network is an opportunity and a challenge for independence of the network from GPS, GNSS, and Galileo for clock and location.

Accurate beam-steering from a satellite to a ground-based user, and the design of antenna array systems with a small enough form factor with the constraints of the satellite size and other constraints, are some further challenges. NTN networks should be designed to meet realistic power ranges for the satellite transmitters and requirements for indoor penetration, coverage, and capacity. Moreover, TN-NTN co-existence should be considered. Low-power enhancements and a common device interface for reduced cost and form factors need to be addressed.

The North American region has been and continues to be a cradle of innovation in space technologies and has pioneered the deployment of satellite-based communication networks. There is a tremendous opportunity to capitalize on this momentum and maintain leadership in the NTN space.

Necessary research areas include new waveforms, modulation schemes, and error-correction techniques, which may be required to efficiently overcome the vagaries of the satellite-to-ground airlink. Cognitive or AI/ML-based techniques for performing dynamic spectral allocation to reduce interference, and the usage of visible light communication [17], are also fertile areas of investigation.

Use-case	In-vehicle	In-robot, in-production module	Intra-body
Application examples	Engine control, electric power steering, ABS, electric parking brakes, suspensions, and Advanced Driver Assistance System (ADAS)	Motion, torque, force control	Heartbeat control, vital sign monitoring, insulin pumping, muscle haptic control
Number of devices	~50-100	~20	<20
Data Rate	<10 Mbps (control) <10 Gbps (ADAS)	<10 Mbps	<20 Mbps
Service Reliability and Availability	99.9999%-99.999999%	99.9999%-99.999999%	99.9999999%
Latency	~ 54 us	~ 100 us	~ 20 ms

Table 3.3.3: Some Use Cases and Requirements for Extreme Networking (updated from [18])

6G networks are also expected to support ultra-high-precise positioning with the error of several centimeters or less [19], as well as high-precision communication subject to extreme requirements in terms of guarantees for throughput, latency, jitter, and traffic flow synchronization [20]. The timing requirements may be at the sub-picosecond accuracy level for several applications and verticals (e.g., electronic trading applications). All these extreme networking requirements are expected to impact several North American 6G leadership audacious goals, including:

- > Advancement of trust, security, and resilience (e.g., through anti-jamming resilient air interface design); enhanced digital world experience.
- > Cost efficiency (e.g., through offering wireless industrial services with wire-like performance).
- > Distributed cloud and communications systems.

An in-depth study of these requirements, aiming at a better understanding of the associated use cases and combinations of KPI extreme values to be supported, within the 6G work scope, will be required.

3.3.3 Radio for Extreme Networking: Industrial, In-Vehicle, In-Body, and Intra-Body

6G is expected to support life-critical services, possibly eliminating wired communication entirely, at least for short-range low-power transmission. The use cases for such life-critical services are subject to communication requirements covering throughput, latency, and reliability that can reach the ultimate values envisioned for 6G in all these KPIs, as illustrated in the Table 3.3.3.

6G can eliminate wired communication entirely, at least for short-range communications.

Various research areas are important to make 6G support the extreme networking requirements envisioned here a reality. Such research areas include the use of special-purpose networks, or short-range and low-power sub-networks (e.g., in-industrial, in-vehicle, on-body, intra-body, or in-house sub-networks). These are either standalone networks or part of larger 6G network infrastructures for the delivery of services under extreme requirements while keeping complexity low for non-extreme requirements, as well as overcoming potential security threats.

Another research area is the support for high-precision communication under network coverage or out-of-network coverage, characterized by requirements for throughput guarantees, latency guarantees, and jitter guarantees for very short transmission time intervals. Given the extremely low latency requirements (e.g., 100 us for some industrial applications) necessitating short transmission time intervals, another challenge is controlling jitters, which can be in the order of 1 ms. It is also important to conduct research in the following areas:

- > Design of ultra-reliable communications including sidelink communications under network coverage (e.g., within mmWave and sub-THz spectrum) and out-of-coverage.
- > Design of jamming-resilient air interface under extreme requirements (e.g., latency).
- > Distributed interference management and advanced duplexing modes.
- > Processing split between edge and devices for high-precision communication subject to extreme latency requirements.
- > Communication and control codesign (e.g., optimization of control applications, taking into account wireless communication characteristics).
- > Joint communication and sensing subject to extreme communication requirements.

North America has significant capabilities in many of the above areas (e.g., edge-computing, and anti-jamming techniques) that could be leveraged for leadership in the 6G era.

3.3.4 Mesh Network and Sidelink

The recent trend of massive increases in mobile device densification is expected to continue and even intensify in the future due to the proliferation of consumer, enterprise, and public safety use cases such as V2X, IoT, IIoT, XR, etc. This allows wireless devices to more easily find and directly connect to neighboring devices to convey local traffic, reduce transmission energy requirements, or increase coverage via sidelink transmissions, possibly over multiple hops. From a system perspective, coverage and capacity extension using less network infrastructure is a strong motivation to support heterogeneous multi-hop transmissions. Introduction

of a mesh framework within the overall system architecture introduces higher resiliency, network scalability, and better load-management capabilities. This topic will explore radio technologies to support evolution of sidelink communications and enablement of the mesh topology in which nodes connect directly and non-hierarchically to multiple other nodes, including network nodes or user devices. A mesh network may be either static or semi-static in nature, or allow dynamic topology changes, in which case it is referred to as an ad-hoc mesh.

Wireless multihop relaying can increase the aggregate network data capacity and improve coverage of cellular systems by reducing path loss, mitigating shadowing, and enabling spatial reuse.

Some of the emerging use cases for wireless communications include simple and inexpensive devices that can be deployed in very large numbers for applications such as:

- > Environment sensing, condition monitoring and motion control.
- > Specialized sidelink-only devices supporting IoT and Ultra-Reliable Low-Latency Communication (URLLC) transmissions for IIoT applications requiring modest data rate and mobility support.
- > Support for XR applications requiring very high data rates, low-latency and synchronized transmissions across multiple devices.

Sidelink operations are currently supported in today's 4G and 5G systems to address mainly D2D and V2X related use cases. But they are incapable of supporting the set of extreme requirements such as mesh connectivity, support for cooperative communications, ultra-high throughput, support for ultra-low cost sidelink devices, etc., that may be required to support 6G applications. Enhancements to sidelink technologies are required to cater to a diverse and challenging set of 6G use cases, deployment scenarios (in-coverage, out-of-coverage), and spectrum types (licensed, unlicensed).

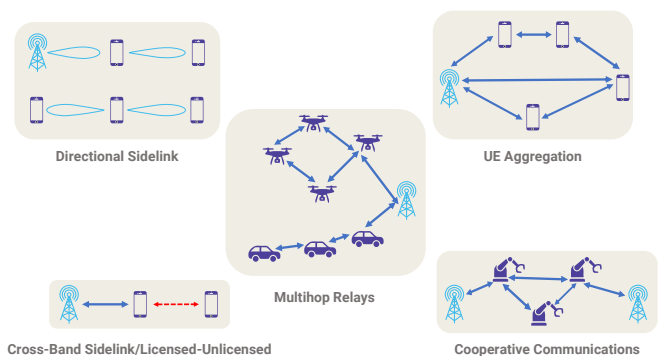

Figure 3.3.4: Different Deployment Frameworks for Sidelink and Device-Centric Mesh Networks

From a North American leadership perspective, the presence of industry players relevant to the overall sidelink ecosystem, representing a broad range of consumer, enterprise, and public safety use cases, provides a strong incentive and opportunity to invest in addressing some of the key research challenges. Some of the opportunities related to sidelink comprise providing enhanced mobility support, support for beam-based transmissions, and enhanced interference management at higher frequencies. Additionally, sidelink design needs to evolve further to cater to a range of extreme KPIs to enable extreme networking, support for time-sensitive networking, and support for a very large number of low-capability devices. Increased robustness and cost-effective coverage enhancements enabled by mesh networks afford more opportunities for utilizing higher frequencies such as mmWave and sub-THz bands.

Challenges confronting sidelink communications include providing low-latency communications over multiple hops and interference management. It is challenging to develop an overarching mesh architecture and associated radio technologies to integrate multiple frameworks such as sidelink, IAB, smart repeater, NTN and others. Robust link and route failure and remediation procedures also are challenging. The system design aspect of mesh networking is another area where North American leadership and investment would be very beneficial due to the availability of higher frequency bands well suited to the use of this technology in existing, greenfield, or hybrid network deployments.

Some of the research areas related to sidelink include distributed resource allocation; peer discovery, selection, and synchronization; and dynamic route and topology management. Another area that requires attention includes power efficiency both for regular sidelink operations, as well as enablement for true low-power sidelink operation and applications.

3.4 Radio Technologies for/by AI and Distributed Cloud

6G is expected to bring a tighter convergence between communication and computing. NGA defined “AI-native wireless networking” and “distributed cloud and communications system” as two 6G audacious goals. As the interface connecting mobile devices and network, the air interface will play a big role in achieving these audacious goals. This section touches on two aspects of air interface and computing technologies interplay: using AI technologies to address air interface challenges and improve performance and using air interface technologies to facilitate distributed computing between mobile devices and networks.

3.4.1 AI-Native Air Interface

In recent years, AI/ML techniques have gained tremendous success in areas such as image processing, speech

recognition, and automatic language translation, etc. while compute capabilities for AI workloads in the network/edge and devices have dramatically increased. Therefore, it’s very compelling to take advantage of such capabilities for the design and implementation of the wireless air interface, too. In the design of the air interface, many tasks occurring at different layers of the air interface can be formulated as optimization problems. A conventional approach to solving these problems, widely adopted in previous generations up to 5G, has been relying heavily on model-based approaches. In contrast, for 6G systems, it is expected that better performance, robustness, and adaptability could be achieved by adopting a data-driven approach by AI/ML. This motivates the focus of the present topic, which is the design of an air interface considering AI/ML techniques from the very beginning. An inherently intelligent air interface would facilitate autonomous network operation and optimization, and dynamically adapting itself to changing environment, which will be crucial for meeting stringent 6G performance requirements.

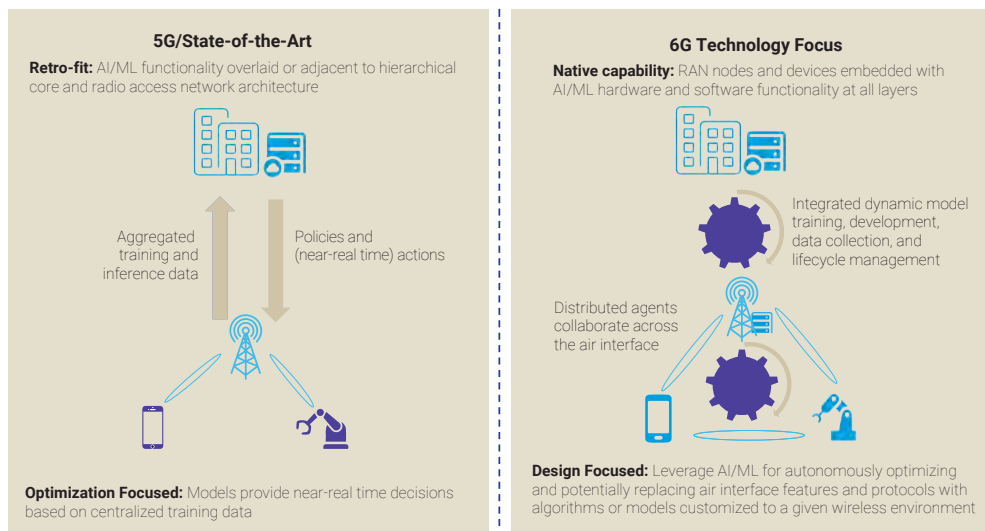

Figure 3.4.1: End-to-end Native AI Concept in 6G

An AI/ML-centric approach in the design of 6G system functionalities will create both opportunities and challenges. In terms of opportunities, traditional optimization aspects like decision feedback and propagation of soft information will be complemented by dynamic, data-driven models that naturally support KPI-improving nonlinear methods. Integrating native AI/ML into the design of an air interface for 6G systems will facilitate joint optimization of network and device operations, and autonomous network operation. Also, AI/ML can leverage maturing technologies (e.g., stochastic computing) when implementing deep layer functionalities such as existing (or new) activation functions. Current ML tools are also evolving to enable complex-valued inputs and parameter propagation. In addition, the data-driven framework in 6G systems will generate a large amount of data that can be leveraged for model training/testing in an AI-native air interface.

In terms of challenges, model training and inference will be computationally intensive, likely relying on advances in distributed, collaborative, and edge computing. Privacy and

trustworthiness will need to be guaranteed when sharing data between nodes. Also, training will require data:

- > Collection (complicated by its inherently distributed nature)
- > Labeling
- > Analysis
- > Transformation and/or preparation

KPIs such as Quality of Service (QoS) and inference latency, communication overhead, device compute capability, and data privacy will need to be monitored. In addition, model building and aggregation will require lifecycle management, including training and development, validation, serving, monitoring, and retraining. Furthermore, a single 6G system may need to integrate disparate:

- > Models and model (hyper)parameters
- > Training and evaluation data
- > Algorithms and environments

AI/ML will be entrenched in the design of 6G's air interface, network and devices. North American 6G leadership is expected to excel and focus research areas on the goal of creating an AI/ML intelligence specific to 6G. That would enable continual and dynamic adaptation of the network and device operations to any hardware, radio environment, application, better use of scarce network resources like spectrum, and improve sustainability of networks.

The transition of air-interface and other network layers to AI/ML is likely to be in stages. As the first step, research may be focused on replacing/assisting the specific functions in network and devices and optimizing parameters of conventional algorithms by tuning their parameters. Gradually, it is expected that AI/ML will design parts of the physical layer while making best use of communication between different network layers, devices, and components. Those capabilities will introduce new research directions to both

5G's evolutionary path and 6G. Some of the new challenges requiring further research are data generation, verification, storage for AI/ML, defining AI/ML model performance benchmarks, ensuring their harmonization with remainder of the network, network-device collaboration, development of offline/online training methodologies, semantic/goal-oriented communication architecture, and new channel modeling approaches to support AI/ML.

North American 6G leadership is expected to excel and focus research areas on the goal of creating an AI/ML intelligence specific to 6G. That would enable continual and dynamic adaptation of the network and device operations to any hardware, radio environment, and application, optimize use of scarce network resources like spectrum, and improve sustainability of networks.

3.4.2 Air Interface Enablement for Distributed Computing and Intelligence across Device and Network

This topic will explore air interface aspects for enabling distributed computing and intelligence across devices and network nodes. This is part of a system-wide effort to address the "distributed cloud and communications system" audacious goal, where mobile device compute and network compute become integral part of the 6G wide-area distributed cloud. As the first hop of connecting mobile device compute and network compute to the 6G wide-area distributed cloud, the air interface plays a critical role in enabling the 6G distributed cloud and communications system audacious goal. This topic will analyze:

As the first step of connecting mobile device compute and network compute to the 6G wide-area distributed cloud, the air interface plays a critical role in enabling the 6G distributed cloud and communications system audacious goal.

- > Joint communication-computing air interface features, such as methods of sharing remote computing/memory resources among 6G devices and network nodes.
- > Dynamic migration of computing workload between 6G devices and network nodes.
- > Compute resource control and Radio Resource Control (RRC) mechanisms considering both radio resources and performance, as well as compute resources and performance.
- > Joint communication and computing performance optimization.
- > Mobility management considering both communication service continuity and computing service continuity.
- > Sidelink and mesh network design for computing workload distribution among mobile devices.

With AI workload as an important type of computing workload, this topic is also expected to enable features to support AI-specific requirements (e.g., distributed training/inference).

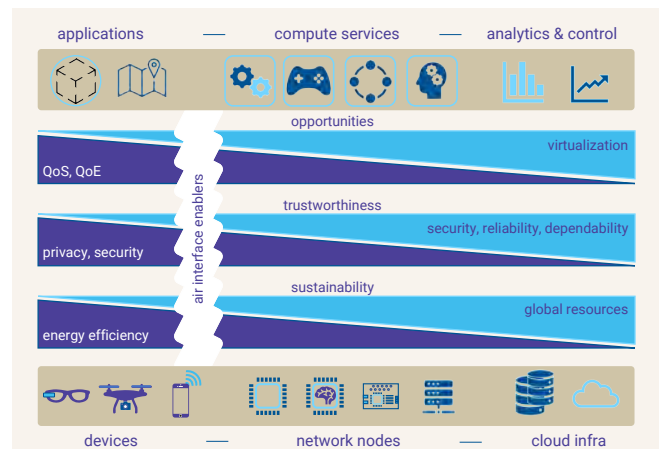

Figure 3.4.2: Air interface enablers for computing workload distribution between device and network nodes with a holistic view of communication-computing performance, efficiency, and privacy/security.

Present mobile systems have been primarily focused on providing radio resources and communication services. Computational services occur above L3 and are separately managed from communication services. Moving into 6G, with the emergence of new use cases and applications, ubiquitous computing and intelligence are required to meet service requirements. For example, immersive XR and sensing applications would greatly benefit from distributed computing due to wearable devices' physical/compute limitations. ML training/inference can be computation-heavy and can be offloaded in a distributed or collaborative fashion. This requires 6G system to take a holistic view of communication and computing technologies and inherently enable features to address challenges in distributed computing and intelligence such as scalability, agility, and performance. The air interface enabler will play an important role as illustrated in Figure 3.4.2. The converged capabilities of communication, computing, and data in 6G systems would trigger the creation of new use cases and market opportunities beyond today's imagination. Besides performance gains, the ability of jointly optimizing computing, communication, and data operations could also bring energy savings and contribute to sustainability goals.

The following research areas will be studied in this topic:

- > Gaps and requirements of the air interface in enabling distributed computing and intelligence across device and network.
 - > Air interface features on enabling distributed computing services and smart resource management in 6G system (e.g., joint computing resource control and communication resource control considering both computing and radio performance requirements).
 - > Air interface features to address specific computing workload requirements (e.g., AI workloads).
 - > Learning model optimization considering radio condition and computing resources.
 - > Channel impact and air interface requirements for cooperative tasks (e.g., federated learning).
 - > Air interface with enabled joint optimization of compute model/data (e.g., ML model) and communication resources.
 - > D2D/local communication/computation impact on 6G air interface (e.g., the uncertainty related to the channel condition and computing nodes failure will need to be considered when deployed intelligence/computing over devices).
 - > Impact on UE communication/computing complexity.
- > Compute-communicate trade-offs and requirements on air interface for optimized energy consumption.
 - > Built-in privacy and security protection mechanisms.

Air interface enablement for distributed computing and intelligence is a key enabler for incorporating mobile device computing into the 6G wide-area cloud and allowing efficient computing workload distribution across mobile devices and network nodes. It is important for North America to invest in this area to continue leadership on cloud computing and mobile communications in the 6G era.

3.5 Radio Technologies for Communication-Sensing Fusion

Sensing for situational awareness is becoming important in many new commercial and industrial applications and services, such as smart-home/-factory/-city, interactive gaming, AR, health monitoring, and automotive safety. Wireless sensing and positioning techniques enable many basic functions for situational awareness, including target sensing and detection, proximity detection, imaging, localization and positioning, and 2D/3D mapping.

As 5G and 6G communication systems extend to mid-band, mmWave, sub-THz, and THz spectrum, it is highly desirable to reuse the spectrum and hardware between the communication and sensing functions and leverage mutual benefits with a coordinated operation.

3.5.1 Joint Communications and Sensing (JCAS)

JCAS is envisioned as a key technology for 6G communication systems to improve mutual performance with coordinated operation of the two functions. JCAS offers mutual benefits for:

- > Coexistence for improved spectrum sharing, hardware reuse, and interference management.
- > Communication to aid with sensing for rich visualization of the environment among many sensing nodes.
- > Sensing to aid with communications for improved performance (e.g., with mobility and beamforming, by leveraging the sensed environment for adapting the transmission and reception).
- > Moreover, JCAS can enhance the positioning performance achievable with standalone cellular and non-cellular based techniques.

JCAS presents several unique challenges and design considerations. Regarding coexistence for improved spectrum sharing, a key challenge is to have a flexible design

that can operate under different communication and sensing performance tradeoffs. Waveform, beamforming design, and resource multiplexing is at the center of this challenge. As an example, JCAS with co-designed waveform may become essential in providing high-rate communications alongside high fidelity (high resolution and update rate) sensing performance wherein a common waveform is used for both communication and sensing functions. Furthermore, the spatial directions of the sensing operation can be different from the spatial direction of the communication link transmission. This presents a tradeoff between the achievable QoS for the sensing and the communication functions. In the cellular system, depending on various sensing capabilities,

JCAS operations can be BS-based, UE-based, or based on both BS and UE. BS-based JCAS can be the starting point given its processing power, transmission power, coverage, potential full-duplex capability, and MIMO/beamforming support. The full duplex operation at BS is the basis for monostatic sensing. Bi-static sensing operation is possible with multiple BSs with synchronized coordination. Similarly, UE/device can also enable sensing in a bi-static manner when full duplex on UE is not yet available. These three types of JCAS operations will provide promising and diverse opportunities to meet various JCAS requirements. Some examples of use cases for sensing and corresponding requirements are shown in Table 3.5.1.

Examples of sensing use-case families	Example application	Example KPIs				Required BW
		Max Range (m)	Max Velocity (m/s)	Range Resolution (m)	Doppler Resolution (m/s)	
Smart Manufacturing and IIoT	Digital twin, mapping industrial environment, etc.	~100-200m	± 9m/s	Cm-level	0.5m/s	~3-5GHz
Traffic maintenance and smart transportation	ADAS	250-300m	± 70m/s	7-30cm	0.1-0.6m/s	~0.5GHz
	Road traffic monitoring	~80-200m	~ ± 20-40m/s	0.5-1m	~1-3m/s	~0.15-0.3GHz
	Parked Vehicle detection	~5m	0	0.5m (< vehicle dimension)	NA	~0.3GHz
	Pedestrian detection	~5m	-3m/s to 3m/s	Tens of cm	Very low	~0.2-0.4GHz
	Around the corner vehicle	~100m	~15	1m (< vehicle dimension)	High	~0.15GHz
Environmental monitoring	Weather Prediction	~200-500	NA	~5m	NA	~0.03GHz
	Pollution Monitoring	~200-500	NA	~1-5m	NA	~0.03-0.15GHz
Human activity/ presence detection	Gesture Recognition	1-cm to ≤1m	-10m/s to 10m/s	Cm-level	~0.3m/s	~3-5GHz
	Human Presence Detection	~20m	~2m/s	Tens of cm, e.g., 0.3 m	~0.1m/s	~0.2-0.4GHz
	Body Proximity	0.1cm to <20cm	~2m/s	Cm-level	High	~3-5GHz
	Obstacle Proximity	~2m	~3m/s	Cm-level	~0.1m/s	~3-5GHz
	Human Proximity Detection	~20m	~4m/s	Tens of cm	~0.1m/s	~0.2-0.4GHz
	Fall Detection	~10m	~3m/s	Tens of cm	~0.1m/s	~0.2-0.4GHz
Remote Sensing	Drone Monitoring, detection and/or management	~500m	~30-40m/s	1m	~5m/s	~0.15GHz

Table 3.5.1: Example Use Cases for Sensing and Corresponding Requirements

Regarding communication to assist with cooperative sensing potentially among many sensing nodes in the network, synchronization among the sensing nodes becomes a major challenge. Interference management is also central to JCAS operation, with the additional consideration of cross-function interference management in addition to communication-only or sensing-only systems.

JCAS is a topic of active research in academia and industry. Key research areas include evaluation methodology to study the tradeoffs between sensing and communication performance, channel modeling for sensing, waveform-beamforming design, co-existence, cooperation and co-design between sensing and communication functions, resource allocation, cooperative sensing, hardware requirements arising for JCAS operation, clutter suppression, UE orientation, Joint processing for multi-static radar, and AI/ML-based sensing fusion. Full-duplex radio is yet another key enabler for monostatic sensing and an important area of research for both high-power BSs and the lower power UE.

The fusion of communication and sensing in 6G RATs presents exciting use cases in various network topologies (e.g., with sensing at the BS and/or the UE). AI/ML technologies can provide interesting opportunities for sensing fusion, where the sensing information can be combined with other sources such as visual information from video/images. With increasing application of wireless sensing, such fusion between sensing and communication functions is expected to provide significant mutual benefits while offering spectrum and hardware reuse between the two functions.

Fusion of communication sensing in 6G is expected to provide significant mutual benefits while offering spectrum and hardware reuse between the two functions.

3.6 Section Summary and Recommendations

In this section, this paper introduces 6G candidate technologies in the radio technology area and discusses various technical challenges, as well as opportunities for North American 6G leadership.

First of all, the evolution of basic radio technologies is one of the most fundamental aspects of next-generation cellular systems having direct impact on canonical system KPIs. With the technologies to support new sub-THz/THz bands, as well as enhancements to existing mmWave band technologies, various enhanced mobile broadband services can be provided to North America. It is also expected that more efficient use of already allocated spectrum can be possible in 6G via spectrum sharing and full duplex technologies. Moreover, various MIMO technology enhancements — including RIS, OAM, advanced massive MIMO, distributed MIMO, and fundamental physical layer enhancements such as waveform, coding, modulation, and multi-access scheme — will improve the actual experienced end user performance in 6G.

The technologies for green network and energy-efficient solutions have been mostly neglected in previous generation cellular systems. In 6G, technologies such as green network, device power saving, and NZE communication will contribute to achieving North America's carbon neutrality goal.

On the other hand, radio technologies for new topology and networking such as UE cooperative communication, NTN, and mesh networking will support various new types of connectivity, as well as continuously evolving network topology for providing adaptive network coverage to meet the varying user traffic demand and extremely wide coverage area in North America.

North America has been the birthplace and the leader of AI. By applying the technical advancement of AI to 6G systems, North American leadership can be extended to cellular communication areas. AI-based air interface design and air interface enablement for distributed computing and intelligence will allow end-to-end native AI and true convergence of communication and computing.

North America has been the pioneer in exploiting higher frequency bands such as mmWave and sub-THz/THz spectrum thanks to the FCC's preemptive spectrum rulemaking such as Spectrum Horizon. These high-frequency bands can be used for communication purposes and for sensing for situational awareness from which new use cases such as autonomous driving and XR, etc., can be benefited. With integrated support of joint communication and sensing in cellular systems, it is expected that further new business opportunities can be bloomed in North America.

4 SYSTEM AND NETWORK ARCHITECTURE

The cellular network concept has been stable for many years and was based on key assumptions that were dependable. The network was flat: both physically in terms of it being 2D and topologically as devices connected directly to the network. The devices moved, but the network didn't. Functions were allocated to certain nodes and stayed there.

Following what was historically considered good engineering practices, the network exploited the concept of information hiding. The protocols were layered with minimal interactions between layers. The communications and computation functions were segregated. The boundaries between applications and the network were clear.

6G is expected to address even more markets than 5G did. Those assumptions that were stressed in 5G will likely break completely in 6G. The network is expected to be quite dynamic, with functions, computing, and data all moving both logically and physically. As data-hungry AI algorithms are introduced to improve the management of the network, information hiding is no longer a plus. For user interfaces and applications to be responsive and interactive enough, the network can no longer be cleanly partitioned from the applications or the cloud.

The following sections identify several key ways in which the system and network architecture is expected to change to enable a versatile and dynamic 6G network.

4.1 Non-Terrestrial Networks (NTN)

NTN [21] [22] will play role in 6G by complementing the TN for coverage extension, especially in remote and rural areas (e.g. deserts, mountains, forests), where it is not economically viable to deploy the fixed infrastructures, and for in-flight communications. Recent advances in reusable rocket technologies, introduction of low-cost satellites, smaller satellites (e.g., cube satellites at Low Earth Orbits (LEO) [21] [22]), and increasing demand for in-flight internet access, vessel tracking, and natural disasters monitoring have already set the stage for using NTN to complement TN connectivity. 3GPP Release-17 will support 5G NR and LTE-IoT using NTN. Hence, there is an impending need to design system aspects and solutions for

supporting NTN for ubiquitous network coverage and device connectivity in 6G.

Introduction of NTN is expected to enable close to ubiquitous network coverage and device connectivity and alleviate the increasing complexity of new network installations. Single devices supporting both TN and NTN access can benefit from the scale of the TN market, greatly improving beyond current cost and performance of legacy satellite terminals supporting proprietary standards. On the other hand, from the network perspective, a service that supports TN-NTN mobility is expected to offer affordable NTN subscriptions with reasonable 6G broadband performance. NTN will contribute to the goals of Digital World Experience as methods to address application-specific end user experience, even in developing and underdeveloped nations, are identified. NTN will also contribute to the goal of Security and Privacy as part of the secured design of the NTN-enabled UEs and new secured satellites.

NTN raises some new challenges in system and network architecture. This includes large round-trip time (RTT), high differential delay (RTT difference between cell-edge and cell-center UEs), and frequent handover and cell reselection, arising from high mobility in non-geostationary satellites. Moreover, supporting a large number of UEs across the cell, with TN-NTN inter-operability and security aspects, also raise additional challenges. Since the incubation of satellite technologies, the North American region has been the leader of research and development of NTN. Maintaining this leadership and continuing cutting-edge research in NTN will reveal new opportunities in 6G. Hence, to maximize flexibility, NTN system architecture design should carefully consider constellation deployments, including number of satellites, along with their orbital locations, satellite landing rights and signals across nations, platform height estimation, and supporting flexible duplexing. Moreover, system architecture design for TN-NTN co-existence, handover enhancements for intra-satellite, inter-satellite, and inter-NTN mobility (including maintaining mobility contexts) in NSGO constellations, and IoT vs. enhanced Mobile Broad Band (eMBB) services for both mobile and stationary devices are also of utmost importance. Solutions need to be secured and diversified to include both Geostationary Orbit (GEO) and LEO satellites, with both Earth-fixed and Earth-moving satellite beams. Finally, from the device perspective, supporting heterogeneous devices, common device interface, and suitable form factors for reduced cost and converging TN and NTN operators at a reasonable cost needs to be addressed.

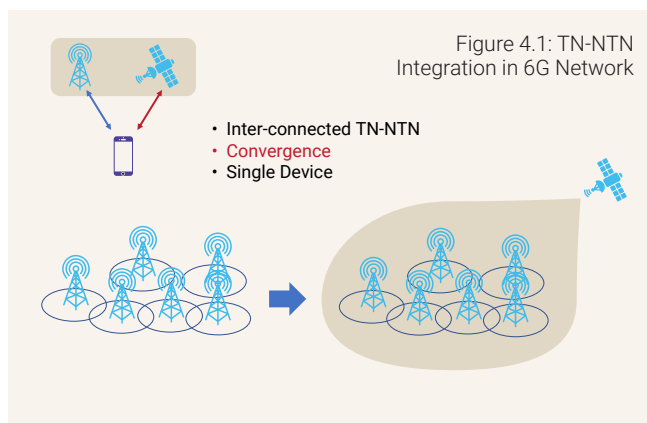

4.2 RAN Topologies – Mesh and Sidelink

There is a need to support ever growing numbers of user devices and use cases such as multi-sensory XR, V2X and local source and sink applications, as well as a need to provide sufficient network coverage at higher frequencies where a large amount of spectrum is available. All of those will require enhancing the capabilities of sidelink communications and introducing mesh topology. This addresses 6G RAN topology evolution to support mesh networks in which nodes connect directly and non-hierarchically to multiple other nodes. Various configuration options are considered for mesh networks such as operation of a mesh node as a network node or a user device, static or semi-static mesh networks, and networks that support dynamic topology changes, called ad-hoc mesh networks.

This includes different coverage scenarios (in-coverage, out-of-coverage) and deployment of different RATs across different transmission legs (such as LTE/NR sidelink, Wi-Fi).

The introduction of the mesh framework will allow network operators to deploy new networks in a cost-effective manner. This will be achieved by staggering network densification to align with user growth and enable and introduce new use cases such as networks of simple and cheap

sensors, enhanced V2X capabilities, advanced industrial automation, and XR. Although it is not yet clear which XR deployment architectures will be widely adopted, they all generally need high-capacity, low-latency communications locally for view rendering and a low-latency link to the application server for multi-user interactions. Both of these motivate the deployment of compute resources at the edge. Further, swarm communications capabilities can enable the next level of applications in vehicular communications such as platooning, UAV/drone applications, and factory automation. These and other use cases require enhancements to sidelink communications and introduction of the mesh framework, which provides higher network resilience, load balancing, and scalable deployment. A dynamic mesh architecture that supports different RATs on different transmission hops, both single and multi-operator deployments, and enables integration with a variety of frameworks at both RAT and UE sides, such as sidelink relays,

Mesh and sidelink technology must tackle various type of communications and deployment scenarios ranging from small data-type applications (e.g., sensors in a factory or in the field) to higher data rate applications (e.g., media distribution in a home environment).

IAB architecture, and a combination of TNs and NTN allows operator networks to be flexible, scalable, and future-proof.

There is a strong need to develop a flexible and dynamic mesh framework that enables network extension solutions and autonomous standalone operations, supports a diversity of mesh nodes that could be either static, mobile, or both, and that may function as data sources/sinks, routers, or a combination of both, with diverse roles and capabilities. Some of the specific research areas include development of dynamic topology and path adaptation techniques based on traffic QoS, providing required transmission resilience and reliability using redundant paths and network coding in a dynamic manner, and mechanisms for dynamic topology failure detection and adaptation. Some of the architecture-related research areas include architectural support to realize infrastructure-less network extensions and autonomous standalone deployments such as a network of sub-networks. Some additional research topics include:

- > Leveraging AI/ML to improve mesh and sidelink operations.
- > Security and privacy procedures for multi-hop transmissions and standalone autonomous operations.
- > Enablement for joint communications and compute view via mesh networking, enabling edge and fog computing frameworks.
- > Support for critical requirements for URLLC traffic, Time Sensitive Networking (TSN), etc.

Finally, mechanisms are needed to enable selection of power-optimized links for battery-critical devices and to provide hooks to enable tradeoff between reliability/resilience, data rates, coverage extension, and energy efficiency within the network.

From the North American perspective, the system design aspects of sidelink enhancements and mesh networking are areas where leadership and investment would be very beneficial due to the vital role expected to be played by these technologies in 6G systems.

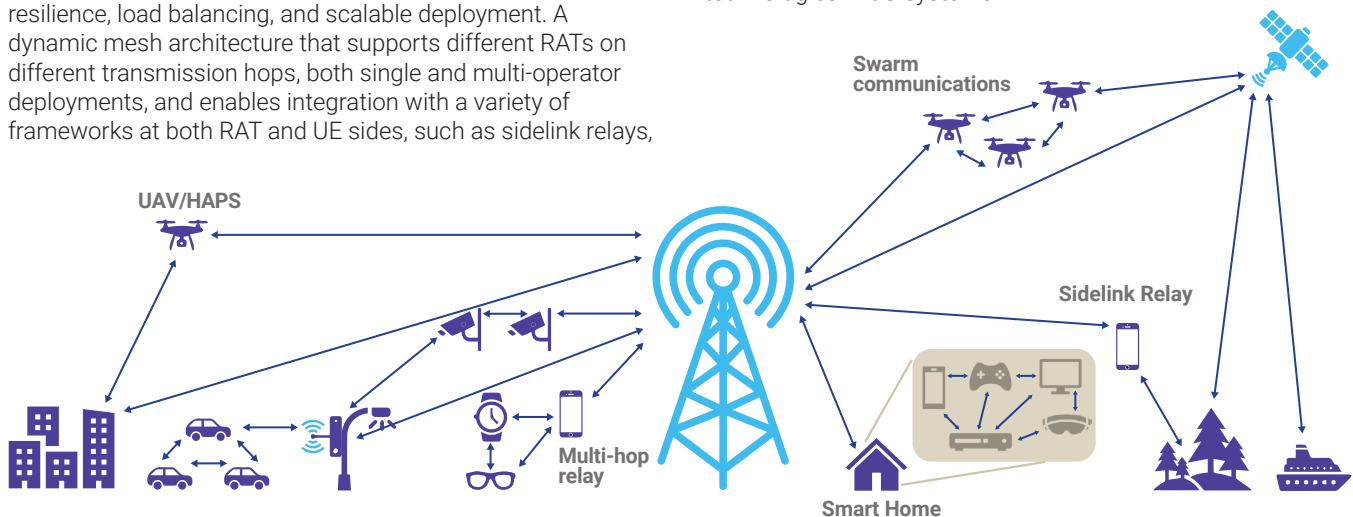

Figure 4.2 Exemplary depiction of a future network deploying advanced sidelink and mesh networking architecture

4.3 Architecture Enhancements for Ambient Intelligence (Aml)

It is expected that advanced cyber-physical control applications will become more important in unstructured settings, such as in everyday assisted living environments and in assisted mission critical environments (e.g., search and rescue, hazardous control). Those applications, coupled with intelligent robots, will require more advanced functional and performance support beyond what 5G and 5G Advanced technologies can support today. Accommodating more complex input from a given environment into decisionmaking and actuation will become a routine behavior of cyber-physical systems, such as service robots as new types of user devices with multi-sensory applications, which will require more challenging design criteria to be satisfied, more reliably, securely, and seamlessly with noticeable increases in data rate and reduction in end-to-end latency. Aml was proposed in 2010–2020 [23] and is the result of the convergence of three key technologies [24]:

- > **Seamless, Pervasive Computing** means integration of microprocessors/cloud servers into everyday objects (e.g., furniture, clothing, vehicles, roads).
- > **Seamless, Ubiquitous Communication** enables these objects to communicate with each other, users, and cloud server(s).
- > An **Intelligent User Interface** enables the users (human or machine) of the Aml to control and interact with the environmental factors in a natural and personalized way.

The resulting landscape is embedded, context-aware, personalized, adaptive, and anticipatory. People will be surrounded by intelligent and intuitive interfaces recognizing and responding to the presence of users.

This topic explores system architectural aspects for enabling Aml across 6G systems, including user devices, RAN, and CN. The focus of the system architectural enhancement is based on use case scenarios where user devices have advanced multi-sensory hardware and applications equipped and require both on-device intelligence and collaborative intelligence through the edge. Examples of such user devices include advanced networked robotics, service robots that support collaborative group operations, and natural forms of interactions with humans or other robots as end users.

With aging populations in many countries, the old-age dependency ratio is expected to rise significantly in the next three decades. According to the UN's World Population Ageing report, old-age dependency ratios were highest in Europe and North America, with 30 persons aged 65 or older per 100 persons of working age (20-64 years) and projected to reach 49 elderly per 100 under 65 years of age in 2050. More advanced and more intelligent machines, such as service robots with Aml, will be able to assist humans, contributing to improving the quality of everyday living. It's important for North America to prepare for societal

sustainability in terms of "population aging" that might cause unstable situations to happen.

In this expected trend, one of the most promising business opportunity aspects for 6G services in the near future is the support of Aml. The business opportunity may include enhanced use of advanced cyber-physical control systems that can help assist human users in everyday living, assist human workers, or replace the role of human workers in unstructured settings or in hazardous environments. The areas that can provide benefits to users include the service tightly coupled with cyber-physical smart applications in a wide range of living environments, such as caregiving (e.g., Continuing Care Retirement Community (CCRC)), shopping, indoor and local outdoor delivery, and private and public safety, such as advanced ambient-powered IoT applications, post-accident response and search-and-rescue. For example, a network of service robots with connected intelligence can play a key role in various living environments of our future society that requires more labor resources to support the aging population [25].

North American leadership in cloud and user interface technologies can be exploited to provide necessary leadership in:

- > Architectural reference model (communication layers inclusive of their affecting applications).
- > Architecture enhancement for autonomous networking that supports Aml.
- > Aml service discovery in cloud-based and standalone operations of functional entities and physical "smart things" (e.g., support of various operational modes of a group of service robots).
- > Highly efficient exposure interface between communication layers and application layers.
- > Smart living and ubiquitous services powered by Aml.
- > Technologies for personalized Aml based on situational context awareness.
- > Aml "environment" for assisted living.

4.4 Network Disaggregation

Network disaggregation, in its broadest term, is the deconstruction of monolithic networking systems into separate components or subsystems, which allow network operators to selectively integrate these components according to differing requirements, technology choices, or different vendor origin.

There are several dimensions wherein such "disaggregation" could be performed. Some examples include:

- > Disaggregation of hardware platforms and software with increasing roles for open hardware and software platforms.
- > Disaggregation through the separation of control, management, and user/data plane functions.
- > Disaggregation of the RAN into components that implement discrete functions at different network layers (e.g., Remote Unit (RU), DU, and Centralized Unit (CU)).

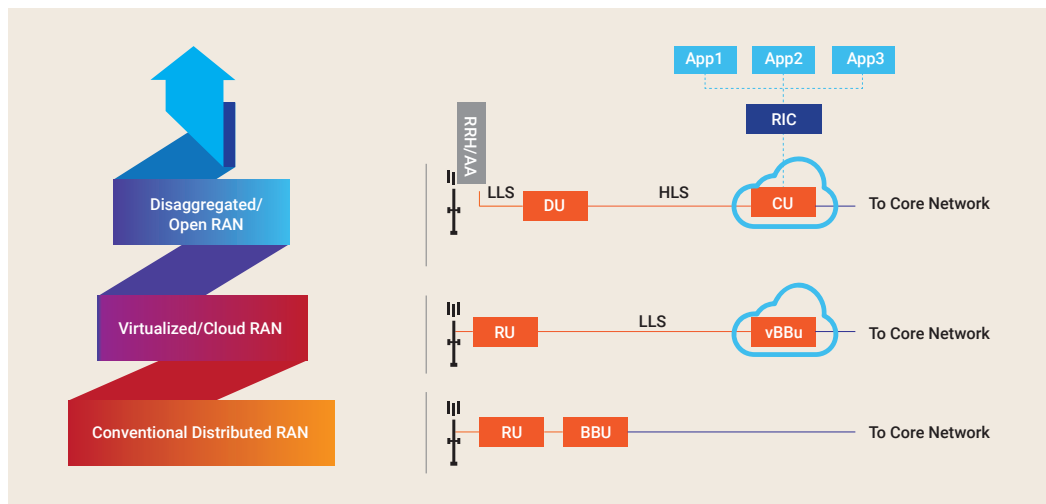

Figure 4.4: Examples of the disaggregation progression in the terrestrial mobile RAN

Potential advantages of disaggregation include flexibility, scalability, cost, and vendor diversity. Challenges to be confronted include additional integration complexity for an end-to-end system, the assignment, distribution, and management of resources among disaggregated components, and the difficulty in determining accountability with failures.

However, despite these challenges, there is a trend toward network disaggregation, including technologies like Software Defined Networking (SDN), Network Function Virtualization (NFV), or containerization, cloudification of the network, open-source centric software, and open interfaces to the RAN, CN, and other network aspects.

The established concept of control and user plane separation will continue to be extended by additional management plane functions that enrich the network with application control, service intelligence, and AI functions through standardized interfaces.

For 5G, network disaggregation work is ongoing in 3GPP, O-RAN Alliance, and other industry bodies. As network disaggregation strategies continue to develop, they stand to become a key aspect of 6G architectures.

Strengths of the community and industry lie in successful realization of cloud and hyperscale architectures that have pushed the boundaries of network flexibility, scalability, and reliability. These strengths have been complemented by innovative semiconductor device technologies to power the cloud, as well as system solutions that serve diverse vertical industry sectors spanning from financial services to health care. In this ecosystem, disaggregation of hardware and software is enabled via technologies such as virtualization and containerization that allow software to be abstracted from the underlying hardware infrastructure.

Examples of the progression of disaggregation as a concept in the terrestrial mobile RAN are shown in Figure 4.4.

In Open RAN systems, the separation of the radio layer through the introduction of an open packet-based transport interface enabled arbitrary placement of the baseband/digital unit, which could then become a software-centric, virtualized Network Function (NF). These entities are instantiated and controlled by a Service Management and Orchestration (SMO) function. This system then becomes addressable through a Radio Intelligent Controller to provide coordinated, automated management and operation of the radio network, in concert with and other applications using defined Application Programming Interfaces (API) or Software Development Kit (SDKs).

With 6G, it is expected that disaggregation will continue to play a key role in the architecture of the network. The established concept of control and user plane separation will continue to be extended by additional management plane functions that enrich the network with application control, service intelligence, and AI functions through standardized interfaces.

Network disaggregation will occur at standard-defined NFs' level and in deployment architectures of those. This enables resource efficient implementation of NFs (their components can be independently scaled, managed, upgraded, placed, etc.).

This movement has already started in 5G, with containerization and cloud native evolution of NFs. However, in 5G this is often bounded by legacy architectures and is far from leveraging its full potential. This trend is going to continue toward 6G and expand into all networking domains (RAN, transport, Core, management). It also will be strengthened by some industry trends (e.g., telco-specific requirements fulfilled by commercial cloud platforms, availability of custom hardware/acceleration through cloud resources, common cloud runtime provided on specific hardware).

To fully utilize the potential benefits of network disaggregation, some technical challenges should be solved while evolving to 6G. Disaggregation should come with the capability of physical separation; that means geo-distributed deployments across sites (including single logical NF's distributed deployment).

Disaggregation and increasing number of possible hosting sites (cloud instances) require proper placing algorithms to determine optimal hosting cloud for components. Furthermore, placing optimization should be provided within a cloud instance, as well, to determine the optimum hosting hardware element (e.g., acceleration card for certain software components).

To what extent the network and its functions should be decomposed will not have a common optimal solution. Different levels of disaggregation will be beneficial in different use cases. Finding the right tradeoffs in the decomposed architecture for various use cases is still an open question on its own.

Within North America, industry expertise and a strong technology development ecosystem will be key to finding ways to practically, efficiently, and securely realize the benefits of network disaggregation.

4.5 UE-RAN-Core Architecture

The system architecture defined in 3GPP Release 15 saw the introduction of many new architectural changes, one of the most significant being the adoption of a service-based architecture for the CN. Specifically, Service-Based Interfaces (SBIs) were introduced for the majority of the Core Control Plane interfaces. However, the interfaces between the UE and Core, as well as between the RAN and Core, remain Point to Point (P2P) interfaces and both terminate at the same NF type for a specific UE, as depicted in Figure 4.5 (a).

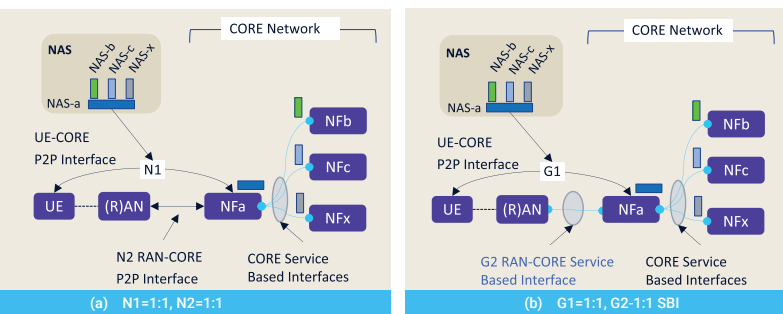

Figure 4.5: Service-Based RAN-Core with Distributed NAS Termination

Adoption of a Service Based Architecture (SBA) between RAN and Core with the current Non Access Stratum (NAS) architecture would bring limited benefits as the RAN would still be constrained to communicating with a single NF type in the Core in a 1:1 fashion as depicted in Figure 4.5 (b). To fully leverage the benefits of an SBA between the RAN and the Core, and to enable the RAN to communicate with multiple NF types in a 1:N fashion over an SBI, the NAS Protocol architecture needs to be redesigned such that it supports Distributed NAS Terminations across multiple NF types in a 1:N fashion as depicted in Figure 4.5 (c).

Distributed NAS Terminations across multiple NF types in a 1:N fashion as depicted in Figure 4.5 (c).

With multiple NFs terminating multiple NAS connections for a single UE, it may be

possible that each of those NAS connections could have its own security context with its own set of keys and integrity and cipher algorithms per NAS connection. This would offer increased security protection whereby a single compromised NAS connection does not mean other remaining NAS connections are also compromised for the same UE.

NF placement is another area that could potentially benefit from this architecture. The increased flexibility and reduced dependency between NF types enables some NF types to be placed at the edge. Other NF types are placed at more regional or centralized locations for a specific network slice, depending on the use case to be addressed.

Adoption of SBIs between the RAN and the Core brings the whole suite of benefits that SBA offers. These include any-to-any communication, a common suite of protocols and paradigms, flexible integration, and enhancement, plus the benefit of having one fewer P2P protocol to implement and support.

In terms of Distributed NAS Termination architectural impacts, there is an expectation that the UE/Chipset, the RAN and the Core NFs will be impacted. For the SBI between the RAN and the Core, there is an expectation of impacts to the RAN and Core NFs only.

Areas that require further research include but are not limited to the following topics:

- > Distributed NAS Termination architectural design, including the scope of functionality that each termination point should support.

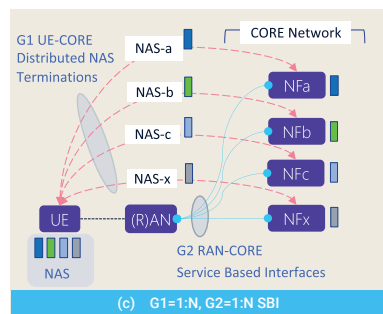

- > Distributed NAS Termination security architecture, including temporary identifiers, key hierarchy, derivation, and distribution.
- > RAN-Core SBA design, including services to be produced and/or consumed by each NF type in the RAN and the Core.

UE/Chipset, security, and SBA designs are all areas in which North America has proven leadership and is well positioned to advance these areas as proposed here in this 6G UE-RAN-Core architecture.

Distributed NAS Termination enables SBI between RAN and Core.

4.6

Distributed Cloud Platform

The built-in computing and data services, the ability to enable a large-scale, distributed cloud in a heterogeneous and ubiquitous computing environment, and the incorporation of device compute all distinguish 6G distributed cloud and communications systems from 5G edge computing.

With the emergence of a broad range of heterogeneous and computationally heavy use cases and applications (e.g., AI/ML, XR, sensing), 6G is foreseen to bring a tight integration of computing and communication. 5G worked on addressing requirements of computationally heavy applications and introduced support for a variety of demanding services such as eMBB,

V2X, and edge computing. However, the communication and computing aspects are still decoupled, and it is not expected that holistic integration of ICT and IT domains will be supported in 5G releases. Such integration will require reconsidering the boundaries of the network to include the edge and the cloud domains and to allow for joint optimizations across multiple domains belonging to different stakeholders.

This topic will investigate 6G system architecture and features to achieve the “Distributed Cloud and Communications System” audacious goal. The goal is to achieve a 6G wide-area distributed cloud system, built on heterogeneous cloud native technology, and optimized for providing ubiquitous computing services. It is envisioned that any node in the 6G system will have computing, data, and communication capabilities. 6G systems shall natively enable distributed computing features with the flexibility of utilizing both in-node computation and distributed computation to optimize resource usage and power consumption while meeting the task’s requirements. The scale of mobile systems can be leveraged to extend computing services from national/regional data centers to encompass network compute and mobile device compute. 6G systems will natively provide computing services and data services in addition to communication services. Data privacy and security aspects have to be incorporated in the system architecture. Computing scaling and workload distribution will be addressed as 6G system functions and capabilities with minimal application impacts. The built-in computing and data services, the ability to enable a large-scale distributed cloud in heterogeneous and ubiquitous computing environment, and the incorporation of device compute all distinguish 6G distributed cloud and communications systems from 5G edge computing.

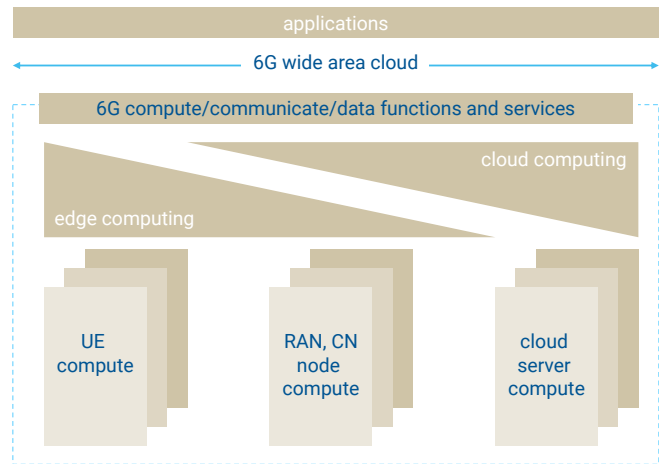

6G distributed cloud and communications systems will transform mobile communication systems from a communication-centric system to communication-computing-data-converged system. Cloud computing will be a tool for building NFs and a means of providing cloud-native computing services. This will enable further computing scaling out from data center and edge computing to ubiquitous computing for empowering new use cases and applications. For example, immersive XR and sensing applications would greatly benefit from distributed computing due to wearable devices’ physical/compute limitations. ML training/inference can be computation-heavy and can be offloaded in a distributed or collaborative fashion. Connected cars can easily find computing resources to support the applications seamlessly. The introduction of value-add computing and data service capabilities in the 6G system will create new growth opportunities for the ICT industry. Energy saving can be achieved by bringing computing closer to data sources. Distributed computing will scale mobile devices’ compute capabilities beyond their physical limits, leading to better sustainability and reduced design costs. Cloud-native technologies and programmable system functions will also potentially lead to Capital Expenditure (CAPEX) and Operational Expenditure (OPEX) savings.

Moving the processing close to the data source will bring new challenges in terms of:

- > Distributed computing service discovery, chaining, coordination, and automation.
- > Interplay between communication and computing functions.
- > Limitations due to dynamic environments (e.g., user mobility).

The 6G system design needs to find the right level of coupling between communication and computing for optimized scalability, complexity, and performance. The heterogeneity of the computing environment and the infrastructure also impose challenges to the system design. The system design needs to accommodate various types of applications/

workloads/computing devices, data privacy, and multiple security and ownership domains. Challenges in supporting collaboration between applications and the 6G system with encrypted traffic flows need to be addressed. Applications with different levels of resiliency and redundancy need to be supported through innovations that bridge over current limitations in network and compute technologies.

Network and cloud providers, application developers, service providers, and device and equipment vendors all have a role to play in achieving the vision of 6G distributed computing. Much of the interaction between players will be automated. Broker-less marketplace technologies will help the ecosystem to scale. Efficient partnering across ecosystem actors can be facilitated by standards that ensure interoperability. The right level of harmonization in the ecosystem is key to supporting scalability, as well as the innovation needed for North American leadership in this area.

4.7 Applications of AI/ML in Networks and Devices

Wireless networks have become increasingly complex to address new technological and operational demands of various industries. The design and maintenance of future networks requires new approaches to optimize resource allocation within radio components and CN functions. One example is solving optimization problems in radio and CNs that are complex, high-dimensional, and/or rely on many statistical variables. Network planning and optimization would benefit from automated AI/ML methods (e.g., for coverage optimization, handover robustness, traffic forecast). Predictive maintenance, failure diagnostics, and forecasting security attacks would also benefit from AI/ML methods. The new industry direction in network disaggregation has increased the complexity and dimensionality of networks, which further emphasizes the benefits that AI/ML could bring.

AI/ML could enhance network operation by tuning available parameters and procedures for the best fit to traffic. For instance, context awareness may be used to predict the best-fitting configuration of lower layers in a radio node, or to provide service proactively based on network-provided models and/or user-specific behaviors. This enhances mobile device performance metrics and helps radio node procedures or NFs. The AI/ML functionality on the device should simplify traditional hardware implementation and procedures by moving more control and intelligence to AI/ML hardware and software. This creates more adaptability of the air interface to various service requirements and network conditions.

Integrating AI/ML into existing wireless networks requires a framework for applying AI/ML to wireless systems. This framework should be able to provide generalized support to different types of AI/ML algorithms, such as supervised, unsupervised, hybrid, etc. The framework should also be applicable to AI/ML integrations at different levels, from replacing an individual function/module to optimizing two or more functions jointly and, eventually, to developing end-to-end, AI-native systems. Once deployed, the performance of

an AI/ML function also needs to be evaluated against preset KPIs, and the model needs to learn continuously for better performance. In the cases when AI/ML models fail to provide expected performance, fallback mechanisms will need to be available as a backup.

Like all other technologies, the introduction of AI/ML does not come without costs, such as extra computational power needed for model training and inference, as well as the associated additional power consumption and possibly signaling overhead. These costs must be weighed against functional or performance improvements.

An open challenge that arises when adopting AI/ML techniques is represented by the lack of ability to describe AI/ML models, potential biases, and their potential impact outside observed KPIs. It will be crucial for operators and vendors (or more in general for AI/ML developers) to be able to understand the decisions made by AI/ML models, measure the impact of their decisions, of data quality, and potential biases. There is the need to develop explainable AI techniques, design principles, and processes that help developers/organizations to add a layer of transparency to AI/ML algorithms so that they can understand their predictions. Leveraging explainable AI techniques, human experts can understand the resulting predictions and build trust and confidence in the results. Explainable AI techniques should include well-defined KPI and metrics and consider multiple AI/

Principles	Description
Accountability	Possible need to control, manage, and audit AI/ML data, algorithms, and design. The data need to be reliable and collected in accordance with regulations. Also, it should be possible to trace any errors and/or negative impact and communicate it to the stakeholders.
Transparency	AI/ML systems must be able to explain which features are used to determine a prediction (e.g., to obtain a logical understanding of the decisions made).
Diversity and Fairness	Dataset used by AI/ML systems should not present bias and/or incompleteness. Processes to detect, understand, and mitigate potential bias are needed.
Robustness and Security	AI/ML systems must be resilient to adversarial attacks such as reverse engineering attacks aiming at inferring model architecture or training data, or as data poisoning attacks.
Governance	It is a key element to achieve fairness and trustworthiness. Humans should be able to manage AI/ML systems throughout their lifecycle.
Privacy	AI/ML systems should protect the privacy and integrity of sensitive data.

Table 4.7: Explainable AI principles

ML-related aspects as described in Table 4.7.

The application of AI/ML in mobile networks may require a certain level of interaction between UEs and the network. This may happen at multiple AI/ML lifecycle stages as in training, inference, and performance evaluation. For example, if an ML model is trained leveraging on Federated Learning techniques, the network and the UEs may need coordination to exchange model updates and to generate a new global model. Another example of interaction is represented by the application of Reinforcement Learning techniques, in which the UE needs to communicate with the network to exchange information, as actions and rewards. A third example could be metrics related to model performance (including data-related information) running at the UE for model-performance monitoring. All this information should be up-to-date and requires coordination with the network to ensure that predictions are reliable and to proactively detect and prevent potential prediction accuracy degradation.

The successful application of AI/ML relies greatly on the availability of relevant datasets. Methodologies and guidelines for data collection, verification, storage, and access need to be researched. The pre-processing of available datasets is also important; the data needs to be appropriate, adequate, and relevant. Common datasets may be needed for comparing AI/ML-based approaches with baseline algorithms, as well as among different AI/ML models. Finally, the confidentiality, security, and privacy of data is crucial for communications systems. Security risks unique to AI/ML-based approaches, such as data poisoning, should be avoided or minimized.

4.8

Lean Protocol Stack

Extreme-throughput, real-time 6G services put significant pressure on the energy consumption associated with the transfer of data.

As 6G moves to a cloud-native approach, there are synergies that can be leveraged to allow tighter coordination between applications and the communication stack to improve end user experiences. For example, immersive services are quite sensitive to issues such as packet loss and data rate fluctuations.

Cross-layer optimizations on the network and device side can be used to assist an application in adapting its QoS requirements to radio conditions and to improve the end user experience. An equally

important consideration is to ensure privacy and security of all communications, which would be a fundamental part of the 6G communication stack.

It is to be noted that the introduction of extreme-throughput, real-time services such as holographic and MR communications, coupled with stricter security requirements, puts significant pressure on the processing capabilities, memory requirements, and energy consumption associated with the transfer of data. The performance of the NR protocol stack is being reviewed in 3GPP today, as issues are being identified with its ability to scale with higher throughput demands. Furthermore, while operation in higher frequency spectrum unlocks the means to achieve increasing 6G throughput demands, the unpredictable nature of these links will require the stack to be able to dynamically adapt to fast-changing radio conditions. General 3GPP requirement: 1 ms latency with service availability five nines

Subnetworks can support replacement of wires among components in a system with 6G wireless connection relied on wired systems.

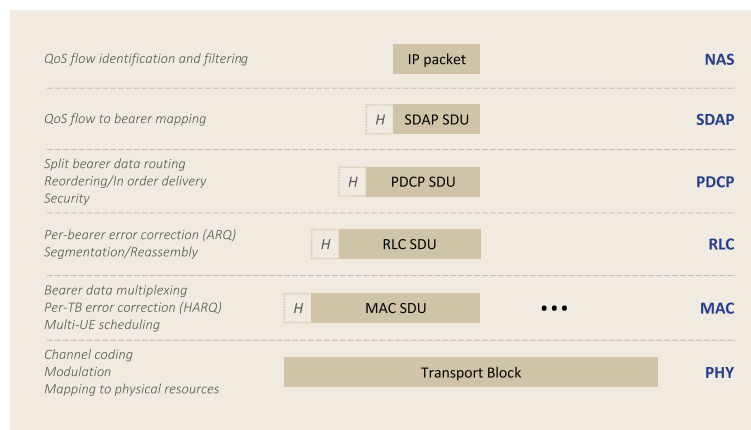

Figure 4.8: NR User Plane Stack Architecture and Key Functionality

North America has always been at the forefront of developing new means to connect people and continues to lead in emerging communication paradigms, such as within immersive environments. To leverage this edge, further research is needed to enable its large-scale adoption, which in turn requires energy-efficient wireless operation. As part of this work, the protocol stack needs to be carefully designed to improve the end user experience while reducing the energy consumption and cost associated with data transfer for the UE and the network. Lessons learned from NR should be considered to ensure that the 6G protocol stack architecture can scale well with increasing throughput and tighter latency requirements. The stack and the physical layer design need to be jointly studied, leveraging synergies where available while simplifying buffer management complexity and overheads. Security procedures need to be incorporated into the stack in an energy-efficient manner. Further study is also needed to enable the stack to dynamically adapt to a fast-changing radio environment. This would include radio awareness of packet-level QoS and application awareness of radio conditions to enable QoS adaptation to tackle user experience disruptors, as well as L1/L3 mobility enhancements to enable seamless and resilient connectivity while reducing the frequency and need of NW-UE interactions.

4.9

Embedded Subnetwork Connectivity

A subnetwork is a network of several devices and one or more access points, which is connected to an overlay network (e.g., Evolved Packet System, 5G System, 6G System, WLAN). If no overlay network is available, a subnetwork can operate autonomously. An access point in a subnetwork supports gateway functionality and is a 6G network and a UE, respectively, from a viewpoint of a device in the subnetwork and an overlay network. The main characteristics of a subnetwork are:

- > Support of extreme communication requirements (e.g., latencies below 100 μ s with service availability above five nines²) [18].
- > Lower transmit power.
- > Star or tree topology.
- > Limited mobility between subnetworks.

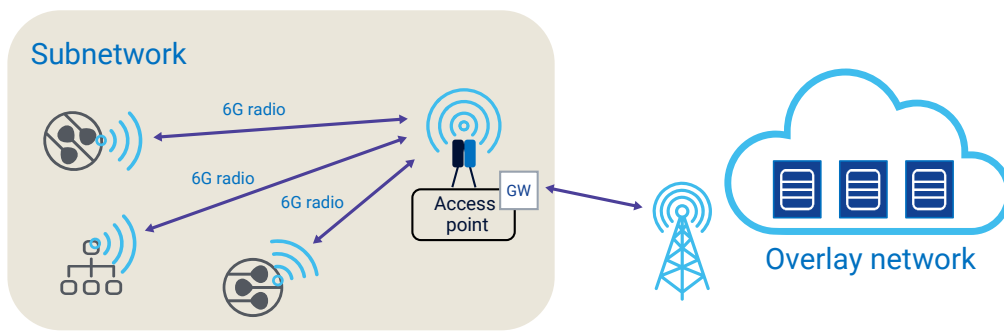

Use of subnetworks avoids the drawbacks related to a wired setup, including higher cost, limited deployment flexibility, and maintenance of cables. For example:

- > If subnetworks are applied in avionics, wireless communications can be used to eliminate the large weight of cables to connect all sensors, controllers, and actuators in an aircraft.
- > In-vehicle subnetworks can replace the controller area network bus and automotive Ethernet operations with wireless, translating to a lower vehicle weight and therefore lower fuel consumption.
- > In-body subnetworks can be installed on the surface (e.g., wristband) or in implants (e.g., brain implant) to ensure the right glucose level maintenance in diabetic patients or to enable movements in patients with motor disabilities.

Support for various applications of subnetworks (in-X subnetworks; with the 'X' standing for the entity in which the subnetworks are deployed) calls for the use of a large spectrum band. According to a performance analysis in [26], in industrial scenarios, several hundreds of MegaHertz (MHz) are required. This means that the licensed spectrum below 6 GHz, commonly used for mobile communications, is not a viable solution. Hence the need for studies into new regulations allowing more flexible and more dynamic use of spectrum and potential use of sub-THz bands. In addition, the installation of in-X subnetwork can easily lead to a dense scenario and thus to potentially high interference levels. Interference management for subnetworks should be proactive and prevent packet losses that might hinder the support of in-X subnetwork use cases.

With the trend of reshoring to North America, high productivity achieved by means of in-factory/in-robot subnetworks and ability to manufacture products with built-in subnetworks (e.g., a car equipped with an in-vehicle subnetwork with less wiring) are pivotal in fulfilling a leading position in the manufacturing industry. Therefore, North America should focus technical leadership in key research topics of subnetworks. Security is of utmost importance in supporting life-critical services via subnetworks. Security in a subnetwork means more than just encryption and integrity protection, but

also protection from attacks aiming at even small number of packet losses, which requires extensive research. Furthermore, AI-enabled policy control and resource management should be studied to accommodate services with extreme requirements considering the spectral availability. Other research areas include (but are not

limited to) coordination between a subnetwork and an overlay network, subnetwork creation and discovery and direct communication between devices in a subnetwork.

4.10 Enhancements to Application Frameworks/ Interfaces and Dynamic QoE Provisioning

The aim of this topic is to investigate application service enablement, along with QoE maintenance and upgrade aspects of the 6G system. One area of focus is to identify new categories of services that are candidates for standardization in the 6G system to support advances in 6G applications and use cases such as those being analyzed in the NGA Applications Working Group. Another focus area is to look at the 6G applications and use cases (such as those being analyzed in the Applications Working Group) and identify what categories of service requirements may be generated by them and how they will be exposed/extracted towards the network. A third area of focus is to investigate interactions of these potentially novel applications and services with the capabilities of the 6G CN and 6G RAN to ensure user-requested QoE can be satisfied. For example, current state-of-the-art technologies rely on proprietary UE frameworks, rather than standardized wireless technologies, to ensure widely differing QoS and QoE application requirements can be met. These proprietary frameworks can be complex, unreliable, and lack interoperability. Newer, and more efficient ways for users to request required QoE that translates into a more dynamically adaptable QoS indicators may be needed.

With expected proliferation of a variety of sensing applications, and specialized subnetworks, there will be a need to support dynamic changes in user policy and allocation of network resources to enable such 6G use case scenarios. A rich framework of advanced 6G application services will also be required that supports functionality such as exchanging metrics that are observable and actionable across intermediate nodes in the 6G system, as well as end-to-end.

The 6G system will require a rich ecosystem of 6G application services integrating with the 6G CN and 6G RAN.

The 6G system is expected to support many new and exciting application use cases such as service-oriented robots, immersive XR experiences, holographic user interfaces, blockchain-based decentralized applications, and personalized user experiences, to name just a few. Connected-device use cases will generate unprecedented quantities of data. Multi-player gaming, group education, and industrial operations are examples of use cases that will involve distributed coordination and collaboration among multiple participants.

As such, the 6G system is expected to be more open, distributed, and data-centric than 5G, with increased in-network application resources (compute, storage, and value-added capabilities, such as AI/ML) that require coordination (e.g., scheduling, deployment, optimization) with network resources. The 6G system is also expected to provide a broad and fair ecosystem that enables participation from a variety of stakeholders in the application, services, and network domains such that one stakeholder does not need to have the expertise of the entire system. For these use cases to become reality in the 6G timeframe and be deployed at scale, the 6G system will require a rich ecosystem of 6G application services integrating with the 6G CN and 6G RAN as shown in Figure 4.10. Therefore, an open and standardized 6G service framework will be needed. Security and privacy are expected to be key challenges in designing this open 6G service framework.

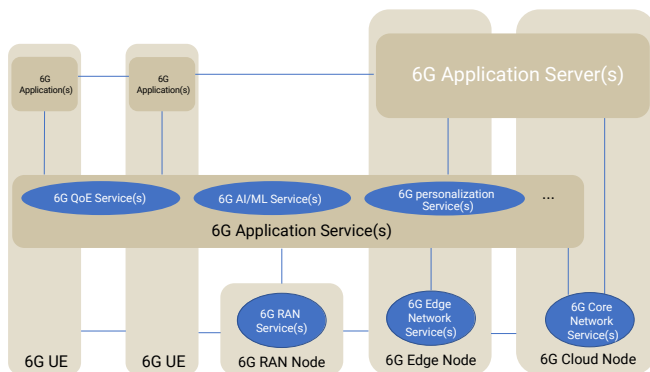

Figure 4.10: 6G Application Services Framework

For example, services that support functionality such as dynamic changes in user policies and allocation of network resources, on-demand QoE provisioning based on application requirements, application service enablement on 6G distributed cloud platforms, automated and accountable service management, user visibility of QoE, and consistent service across networks through seamless roaming and across tiered upgrades.

In addition, services to enable applications to configure, train, deploy and manage AI/ML models in the 6G system, services to automate and assist applications and users

in establishing end-to-end trust, security, and data privacy with each other, services that provide near real-time secure customization and personalization of applications, devices and networks for individual users based on context of the user (e.g., user's identity, user's surrounding, user's emotional state), services that enable applications and users to incorporate and/or use lower-level services supported in the 6G network (e.g., integration and use of network-based AI/ML, computing/data services in the distributed cloud platform, and/or network-based data storage services), and services that provide just-in-time scheduling and deployment of application components across the 6G distributed cloud and communications fabric (device, in-network, customer-premise, edge, and cloud) also need to be studied.

North America has always been at the forefront of introducing new applications and services that take advantage of the new generation of cellular networks (e.g., broadband data communications, videoconferencing, and video on demand). It is important to maintain this leadership in the 6G era, as well.

Given the rich ecosystem of cloud service providers, application developers, device manufacturers, infrastructure, and network providers, North America is in a unique leadership position to define the application framework, services, and interfaces that will open the door to new unique use cases for 6G.

4.11 Section Summary and Recommendations

The previous sections have identified several technologies that are expected to be key in evolving the system and network architecture.

The traditional terrestrial concepts will be expanded with satellites and other aerial platforms to provide alternative coverage.

Topologically, mesh network and embedded subnetworks that break and then extend the cellular concept will be introduced by adding new connectivity options.

The boundaries on where computing happens will dissolve with computing and data storage occurring where it makes sense.

AI is considered a key technology to enable the network to be both manageable and dynamic enough. Thus, the network must provide support for AI at all the various places it will be used, from applications to network operations.

And finally, the rigid allocation of functions must be replaced by more flexible architectures and protocols that accommodate the diverse environments and use cases that 6G will demand.

5 NETWORK OPERATIONS, ADMINISTRATION AND MANAGEMENT (OA&M) AND SERVICE ENABLEMENT

The 6G system is envisioned to increasingly embrace intelligence empowered by AI/ML and data in almost every aspect of the end-to-end system, with the indispensable enablement of AI/ML operations and data management by OA&M.

For decades, OPEX has dominated the total cost of ownership of mobile networks. Thus, it is imperative for OA&M to continue evolving in terms of autonomy, automation, resource usage, and energy efficiency for 6G systems.

In 6G, the OA&M also plays a pivotal role in ubiquitous computing enablement, 6G service assurance for diverse vertical industries, and providing personalized experiences for end users, via more dynamic and fine granularity resource orchestration and QoS control.

It is also expected that the unprecedentedly digitalized experience of 6G OA&M capabilities and 6G services will be enabled for operators and consumers by harnessing the digitalized technologies (e.g., digital twin).

The 6G OA&M also needs to ensure the 6G system can fulfill the expanded social responsibility for public safety in emergencies and disaster recovery.

All of these drive the revolution and evolution of the key technologies for 6G OA&M.

5.1 Service Management/Orchestration, Data Management, and AI/ML-based Intelligent Network Controller for Automation

In 6G, OA&M provides fundamental and essential capabilities to enable and assure the diverse services, provide a better user experience, and operate the 6G system efficiently and cost-effectively. To support ubiquitous computing services and empower extensive AI/ML in 6G system, the management plane and control plane need to be closely coordinated, intelligently coupled, and jointly designed. This topic examines the OA&M capabilities for the 6G system, with a focus on management and orchestration of 6G systems (including NFs, site infrastructure, and 6G services such as communication services, computing services, and data services), data management, autonomous network operation, and AI/ML-enablement for 6G systems that includes interactions with 6G control plane functions and air interfaces.

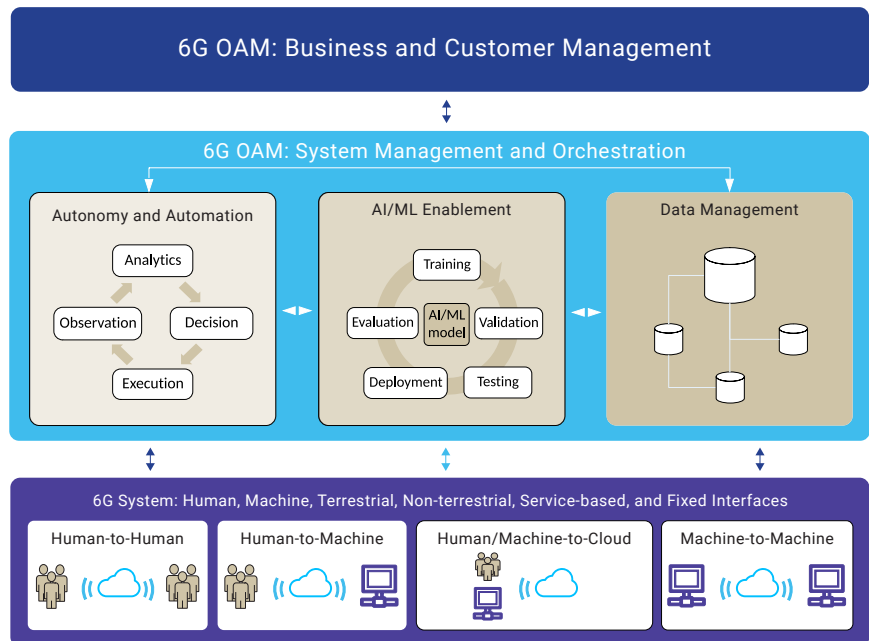

Figure 5.1: 6G OA&M System High-Level Framework

For achieving the “AI-Native,” “Distributed Cloud and Communication,” “Cost Efficient,” “Resilient and Reliable,” “Sustainable,” and “Digital World Experience” oriented audacious goals for 6G, the following aspects are of high importance for North American 6G leadership with respect to service management and orchestration, data management and system autonomy, and automation:

1. **Autonomy and Automation:** The autonomous system intelligence needs to continue to evolve, endowed with self-CHOP (Configuring, Healing, Optimizing, Protecting) enhancements for promoting flexibility, extensibility, feasibility, granularity, and adaptability for 6G. The OA&M subsystem, enabled with autonomous system intelligence, has system-wide scope for a realization of end-to-end system automation in closed loop (throughout observation, analytics, decision, and execution), without requiring human intervention for network operation.
2. **AI/ML Enablement:** The AI/ML capabilities are expected to be used everywhere for 6G, including both in the 6G system and in the 6G OA&M subsystem. The 6G OA&M subsystem needs to provide all the necessary management capabilities throughout the entire AI/ML workflow, including AI/ML model training, validation, testing, deployment, and

6G OA&M is expected to provide fundamental and essential capabilities to manage the data and enable AI/ML for achieving intelligence, autonomy, and automation of 6G systems (including management and orchestration).

evaluation, for enabling the AI/ML capabilities, with consideration for all possible and necessary learning methods.

3. **Openness and Programmability:** The trend of network virtualization and softwarization, including disaggregation of RAN into several software defined components, is anticipated to continue and evolve. The OA&M subsystem needs to have a common architectural framework that enables the 6G system to be programmable, open, and interoperable in a multi-vendor environment.
4. **Ubiquitous Computing Enablement:** The 6G system is designed to support ubiquitous computing. The allocation of resources (computing, networking, and storage) for the computing services requires appropriate OA&M capabilities. These resources need to be orchestrated from an OA&M perspective and be controlled from a system perspective in a cognitively coordinated manner.
5. **User-Centric Personalization:** The 6G system needs to allow users to customize their own QoE and orchestrate the services and networks to adapt automatically to suit a given user's preference. The 6G OA&M subsystem needs to support orchestration, configuration, and an appropriate customization of the 6G system, to suit the personalization of user services, aligned with the system state.
6. **Data Localization and Federation:** In 6G, data need to be available and manageable anywhere. Local data processing and analytics are necessary for prompt OA&M reactions, which require instant (e.g., event-based, threshold-based, periodicity-based) data collection and distribution. Because it may not always be feasible to move data in real time for computing purposes, data sharing or data federation become a necessity for management coordination.
7. **Digitalization for OA&M:** Digitalization in the 6G system paves the way for advanced and unprecedented OA&M capabilities. For instance, a digital twin of the system provides a real-time, holistic vision enabling insights for prompt and accurate management actions. The digitalization includes data encryption, compression, transmission, ETL (extract, transform, load), and all steps of data service.
8. **Enhancements of management capability exposure:** In the 6G system, different management capability exposure levels and permissions are expected, based on the deployment of third-party applications and consumer type. The management capability exposure needs to accommodate dynamic application-layer adaptations, as well as cope with dynamic network conditions and availability changes, which may affect the real-time application service operation.

To attain global 6G leadership for North America on these aspects, the following areas of research are anticipated:

- > Autonomous mechanisms for automation advancements, through closed-loop feedback control and cognitive adaptability.
- > Technical enhancements for enabling and controlling AI/ML through the entire AI/ML workflow, with considerations for all relevant and necessary learning methods.
- > Coordination among the management plane, control plane, and air interface for enabling communication/computing/data services.
- > Evolution of the 6G system from an end-to-end openness and programmability perspective.
- > Data management, including its collection, marshalling, sharing, pipelining and federation.
- > System orchestration, configuration, and customization to provide a personalized experience.
- > Technologies and solutions for digitalization for OA&M.
- > Exposure enhancements for enabling a tight integration between management services and third-party applications.

5.2 Public Safety in Emergencies and Disaster Scenario

The challenges of building and maintaining networks for public safety in emergencies and disaster scenarios are varied as the threats to civil society. The same networks needed to support first responders with everyday incidents such as a police wellness check, a barbecue fire, or person with chest pains need to expand exponentially, even while possibly damaged and overloaded when handling hurricanes, natural gas explosions, wildfires, acts of terror, and a myriad of emergencies not listed here.

When possible, the public and its first responders need to be alerted before the event. This requires mostly mass communications, but also communications focused on safeguarding specific assets and people who are at risk, needed, or problematic during a disaster. Then during the disaster, communications services need to be sufficiently hardened to withstand damaging forces, both physical and logical, and possibly self-reconfigure themselves around damaged elements in order to maintain services. Finally, after a broad area disaster event, rapid network recovery is essential.

6G network ecosystem architectural, technology, and feature robustness are essential for the first responder community and the public during emergencies and disasters, and can be leveraged as monetized enhanced features in everyday applications.

Some potential use cases are earthquakes, forest and brush fires, floods, tornadoes, gas main explosions, hurricanes, tsunamis, acts of violent terrorism (bombings, contaminations, EMPs, etc.), cyberattacks, and other direct acts of war. Recovery from any of these is challenging, especially when they are coincident. The planning of the OA&M for these situations is going to be key in both a recovery mode, and as a deterrence to human actors who may use or leverage such events to our detriment. Rapid network recovery after a broad-area disaster event is something that each research area needs to consider when offering their expertise to the development of a 6G communications ecosystem. Each research area should plan to analyze their robustness in minimizing the impact of these event types while also examining how recovery could best proceed.

The size and scope of the “low or no service” area will drive the network recovery process. Physical resources may be limited, so there will be a need to allocate them judiciously and differently across the physical recovery landscape and its timeline. In short, a “one size fits all” recovery model for each

functional element needs to be challenged. Having multiple methods or paths to restore a particular network functional element, whether it is software or hardware, is going to allow network operators, government, business, and even private citizens to organically restore services. The key point is that our 6G network ecosystem needs to engage each of these sectors collaboratively in order to harden the network by design. The challenge will be to engage these traditionally diverse sectors to integrate organically restored elements with the mainstream and stable portions of the infrastructure network during the recovery process and timeline.

In an ideal situation, the network context and data need to be backed up in real-time in the cloud without the operator’s manual configuration for the backup of individual nodes. They also should be reloaded automatically from the cloud to restore the services seamlessly when the surviving and repaired infrastructure is then powered up. Such a recovery mode is possible for areas adjacent to undamaged network infrastructure as it depends on connectivity, power, and physical infrastructure at the restored service sites and in the access to them. The notion that the cloud will be there with an abundance of access bandwidth and processing channels is viewed with real skepticism in the emergency response community. First responders have heavy confidence in, and reliance on, push-to-talk, direct peer-to-peer communications for many tactical situations. As a result, the industry needs to explore more fully ways to restore the complex services in both a traditional progressive center to edge restoration model, as well as in a localized organic model.



Figure 5.2: Restoration of 6G Network and Services

Ideally, a network and its services need to be restorable with as little manual effort as possible and with the ability to track the progress of the overall emergency response itself. The reliance on a single restoration model will delay the availability of the most essential services and can result in the furtherance of damage, suffering, and death. By having methods to organically restore pockets of recovered communications, the limited local resources within an area can be brought to bear in advance of outside assistance and reduce negative impacts. The reality of most large-scale emergency responses is somewhere in the middle, with both progressive and organic recovery activities each occurring in parallel until they eventually converge. The OA&M for “stitching” of the nodes (VNFs and PNFs) back together into a normalized functional network environment is both interesting as it is challenging and will require an abundance of both technology and operations research.

To get the perspective of potential 6G network ecosystem needs for public safety in emergencies and disasters, consider the areas of sustainability and security.

Sustainability

From a public safety emergency and disaster standpoint, the context of “sustainability” takes on several new meanings beyond “going green.” It means business operational efficiency day to day, while continuously validating readiness for emergency and disaster “surge” demands. It means keeping first responders and the public safe and alive when there are threats, both natural and human-caused. It means having the ability to be informed and dynamic in the performance of the emergency and disaster missions. It also means being able to stand up a basic isolated or minimally interconnected network with limited resources and essential users while incrementally and non-disruptively restoring services over time in various scenarios. These might include situations where the grid is unavailable or connection to the cloud is not available either.

Security

Security is an area rich with challenges and opportunities. In a widespread disaster, one may need to spin up an isolated network using local, limited infrastructure to sustain VNFs and PNFs. How does one do that efficiently and securely? How does one authenticate users, applications, and new infrastructure in an isolated network environment? How does one non-disruptively integrate an isolated network into a mainstream network as services are restored? Then after the emergency, what secure means and tools does one have to audit and assess the isolated network and its operation during the emergency? Furthermore, if the isolated network was compromised by bad actors, can it be determined whether they or their threat vectors found their way into the broader network, and are they still active?

For North America to play the leading role in emergency services, disaster recovery, and service continuity for public safety, sustainability and security are the areas needed to research in the 6G network ecosystem development. Furthermore, their implementation in emergency services, disaster recovery and service continuity, will likely influence customized QoE measures in other 6G applications and services.

5.3 Technology Enablers for Business Services Transformation

Technology is an enabler that provides the means to create and make a difference, ultimately bringing lasting progress and radical transformation. Digital enablers allow organizations to harmonize, synchronize, integrate, visualize, federate, and analyze data to power digital transformation and develop new, value-added services, as well as digitally enhancing older technologies and applications. Other enablers include governments, regulatory bodies, and other organizations that facilitate technology adoption through standards, guidelines, policies, funding, and investment.

Business service enablement usually describes a program of creating or acquiring the services that an organization needs to integrate mobility and digital to start using enterprise service bundles for specific purposes.

To enterprises, 5G has represented a supplementary route to cloud data centers and global business services with promises of superior performance through enhanced mobility, security, and ancillary processing facilities, including the bridging of IT and OT processes within automation. These ambitions can be realized with 5G with the SBA. As transitions from 5G toward 6G take place over the next decade, the ease of transformation will need improvement, especially as backward compatibility with legacy systems is maintained and the bigger promises of 5G and 6G to offer a high QoE across available spectrum assets and deployments are met. It is not too surprising that the promises of 5G, even as they are clearly achievable, are challenging to realize, given the scope of the transition from 4G. The 6G readiness shall be based on how business services created and run under 6G perform, what form the operational UI shall look like (e.g., the degree of autonomy), the method of interface between services and network, and how a wide variety of business services may converge to take full advantage of corresponding offerings.

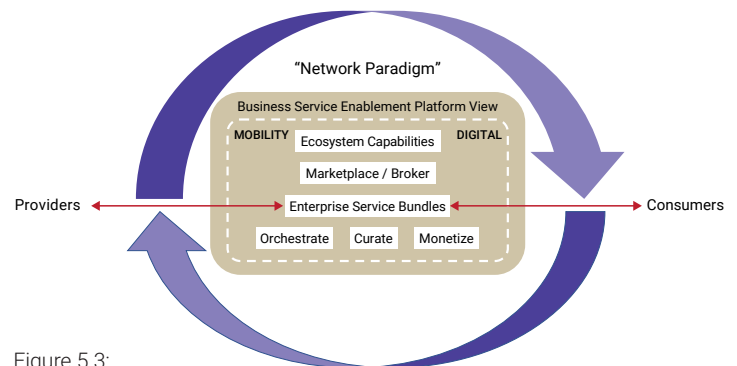

Figure 5.3: High Level Business Service Enablement Platform View

From an OA&M perspective, the broad principle is to progressively build a platform of reusable technologies and to establish projects to collect common services over time. Finding a shared foundational orchestrator of orchestrators horizontal platform with clearly categorized components for service convergence is a viable way forward.

A good example would be IoT service enablement platforms. They provide management of connectivity, devices, and sensors. This includes activating, on-boarding the device, and performance monitoring of the M2M devices. Sensor data provide advanced analytics for control decision and usage analysis.

For the implementation of service enablement in an OAM subsystem with the advent of 6G, more advanced but established technology can be further evolved or transformed. A few big-ticket items to highlight would be:

- > Digital composable autonomous collaboration platform.
- > Advanced Tools for privacy and safety online.
- > Analytics and adaptive technologies in network management & orchestration.
- > Cloud infrastructure.
- > Cloud infrastructure which allows networks to move their hardware & software away from physical locations and make them available anywhere.
- > Mobile devices which can enable access to content and activities anytime anywhere.

Although these items have been made possible with 5G or its predecessors to a certain degree, 6G offers the opportunity to make them ubiquitous.

The underlying enabling technologies propelled by 6G to advance service enablement in OAM subsystem include:

- > IoT sensors and biometrics – Identity Management.
- > Autonomous logistics - gear from data centres auto-sending logistics to cloud.
- > Blockchain and distributed data – Security.
- > Computer Vision – used to interface with IT for troubleshooting & other purposes.
- > Voice Recognition – voice user interface for OA&M system & service.
- > Robotics – QoE in using OA&M system and services.
- > AR/VR/MR/XR – QoE in using OA&M systems and services.
- > End-to-End QoS via dynamic network slicing.

Recommended research areas for North America to gain leadership may include:

- > Natural language used in simple & federated searches.
- > How to develop the ability to drive self-improvement in processing models to further decrease human interaction over time in OA&M sub-system.
- > Time-sensitive communications (e.g., for cross-media synchrony & isochronous systems)
- > Distributed computing, spatial computing, and ubiquitous intelligence.
- > Technology fusion (communication, computing, and data fusion).
- > Common exposure interfaces for network performance.
- > Common platform approach to rapid customization of services (adaptability, re-configuration).
- > Fusion of data, integration of AI/ML into service workflows.
- > Self-Sovereign Identity and/or Blockchains to possibly replace all passwords.

5.4 Energy-Efficient Green Network

Green data center networking at first might seem like a separate topic from sustainable mobile networks. However, modern mobile networks are undergoing a transformation. As Figure 5.4 illustrates, a typical mobile network can be broken down into four main parts: end-user devices like smartphones and IoT devices, the RAN, the CN, and the data center network/cloud.

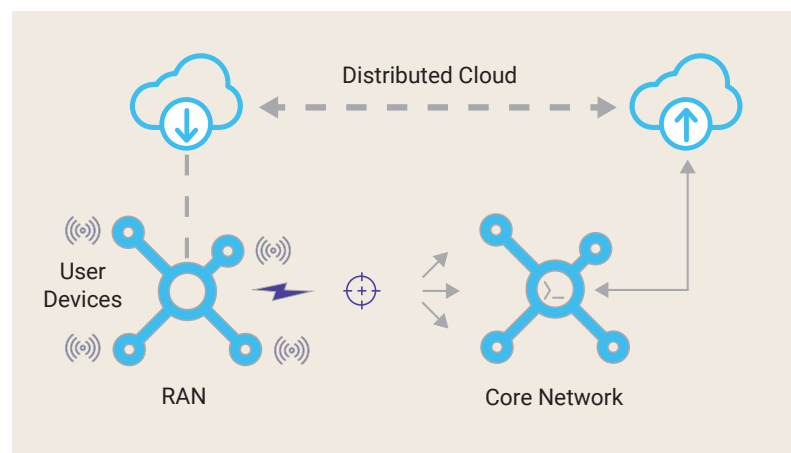

Figure 5.4: Simplified Overview of the Structure of a Typical Mobile Network (as presented in The Path Toward Sustainable 6G white paper [1])

Network functionalities are increasingly being moved away from specialized hardware and toward virtualization. The CN was the first to be virtualized, but it is rapidly spreading to other parts of the network like the RAN and edge. The trend is toward complete virtualization, with the Core, RAN, and edge running on software. This means that the line between telecommunications/mobile networks and the ICT industry as a whole is becoming blurred. With network functionality increasingly being moved into data centers, their share of network energy consumption is projected to grow almost fivefold. So, the footprint of the entire ICT industry must be accounted for, rather than focusing only on the historical definition of the telecommunications industry. Sustainable 6G will rely on sustainable data centers and digital infrastructure.

The line between mobile telecommunication networks and the ICT industry as whole is becoming blurred. The footprint of the entire ICT industry must be accounted for, rather than focusing only on the historical definition of telecommunications.

The single most impactful step that may be taken is transitioning data centers to operate entirely on renewable energy. This is challenging, however, as renewables can have intermittent availability. Opportunities in this space include grid-interactive batteries and intelligent workload management (e.g., deferring low-priority jobs to times with lower emissions). Grid-interactive batteries are charged with renewables and used to protect against voltage and frequency anomalies, optimize energy usage, manage power and the flow of energy, and support the grid to allow higher penetration of renewables. They also provide emergency backup power during blackouts or if the grid is not available during disasters. The same principle also applies to edge sites and to RAN sites.

Additional opportunities exist in improving backup power. Many backup power systems are diesel. More sustainable options being investigated, including hydrogen fuel cells and other advanced battery technologies.

Finally, data center cooling is a significant use of energy and water. Approaches to reduce water usage for data center cooling include geothermal temperature regulation (e.g., building underground data centers), geothermal heat pumps, using river water or seawater for cooling, and having closed loops with water filtering and cooling powered by renewable energies, but avoiding releasing used water that would be warmer and potentially polluted back into the environment. OAM can also help reduce energy and water consumed by monitoring the overall environment and system, optimize temperature, and analyzing water and energy usage, taking into account ambient metrics, weather or traffic usage predictions, or performing heavy operations like backup during cool days.

As a major player in the data center industry, North America must drive innovation to achieve the vision of energy-efficient green networks. Research priorities include:

- > Innovation in green networks and data centers, virtualization, network management techniques.
- > Technology to accelerate the transition to renewables in mobile networks and data center infrastructure.
- > Increasing reuse/recycling of waste and water in data center (and other infrastructure) operations.
- > Research optimization across the radio and CN architecture, with new protocols and AI-based networks and service automation that minimize any unused resources and provide just-in-time network connectivity to meet the capacity needs of what is actually required.
- > Research how the 6G end-to-end system can treat energy as a first-class metric, and design future networks to provide accurate, high-fidelity, and real-time/near-real-time data on energy consumption.
- > Research in safe and green energy interactive grid batteries and backup systems for mobile networks.

5.5 Section Summary and Recommendations

Innovation, evolution, or adaptation is needed for manifold technologies to make 6G OAM vision a reality. The technologies involve AI/ML, autonomy and automation, data management, digitization, programmability, orchestration and control coordination, personalization, time-sensitive operations, service customization, Self-Sovereign Identity (SSI), management capability exposure, energy efficiency, and sustainability and security for public safety.

To strive for the leadership and success of 6G for North America, research on the following areas is recommended:

- > Enablement, control and optimization of AI/ML for 6G system and services.
- > Advancements of end-to-end autonomy and automation.
- > Coordination among the management plane, control plane, and air interface for enabling ubiquitous computing.
- > Systemwide openness and programmability.
- > Data management including data collection, marshalling, sharing, pipelining, and fusion/federation.

- > Dynamic orchestration, configuration, and customization for network personalization.
- > System digitalization and its management.
- > Enhancements of management capability exposure.
- > Sustainability and security for public safety.
- > Application of natural language in OAM area.
- > Management of self-sovereign identity and blockchains.

- > Acceleration of transition to green and renewable energy in data centers and networks.
- > Minimization of unused resources and energy in 6G system.
- > Design of future networks to provide accurate, high-fidelity, and real-time metrics on energy consumption and carbon footprint.
- > Build safe and green energy interactive grid batteries and backup systems for mobile networks.

6 TRUSTWORTHINESS – SECURITY, RELIABILITY, PRIVACY, AND RESILIENCE

Trustworthiness is an expression of confidence and is realized at a high level as a sentiment. In the case of engineering systems, including networks, this paper defines trustworthiness as the confidence in the ability that a system performs as expected in the face of environmental disturbances, impairments, errors, faults, and attacks. This definition of trustworthiness has several proof points specific to the establishment of ICT and pertinent to 6G:

- > Business processes and economic value chains organized in a manner that does not create doubt or lack of confidence in equipment, actors, and processes associated with network services.
- > Diligence in developing open standards that can be tested and certified for consistency with well-defined requirements.
- > Networks and associated services that are secure, privacy-preserving, reliable, available, and resilient.
- > Assurance that the network equipment and associated services are interoperable across the ecosystem and that networks are deployed and operated in accordance with expectations of users.

The above proof points have been quite relevant to all generations of telecommunications technologies and have traditionally been interpreted in accordance with the needs of the services that have been provided. As mobile communication systems have evolved from the telephony era to the Internet, the demands on security and reliability have progressively increased. An example is the importance of accurate location for emergency services in the face of greater dependence on mobile telephones, along with the disappearance of the Public Switched Telephone Network (PSTN) from many residences. Another is the reliance on the mobile phone's capabilities in offering greater confidence for verification of subscriber identity for access to services or for banking and payment processing. Most notably, the proof points consider procedures and technical solutions that address the following objectives:

- > **Cybersecurity:** protection against active and malicious attacks and exploitations.
- > **Availability/resilience:** continued operation in the presence of subsystems failures.
- > **Privacy:** safeguard of privacy related information and compliance with privacy regulation(s).
- > **Safety:** denoting risk of personal or societal harm.

The 5G system was designed to expand the reach of ICT technologies beyond human-centric needs. The introduction of 5G and the creation of a 6G network promise to make telecommunications far more integrated into all interactions within human society, reaching into the realms of automation of societal processes, industrial automation, utilities, transportation, safety, security, entertainment, etc. The introduction of AI as a tool in many computational tasks and the integration of distributed cloud technologies into telecommunication networks suggest that the 6G network would use AI and distributed cloud computation for all services, including internal network workflows and external service-oriented tasks.

Such a future will need re-examination of the security and availability of services. Data privacy must be supported, allowing third-party software services to protect proprietary information such as data and AI models even as AI is used by the operator to improve resilience by means of anomaly detection and mitigation. When cloud-based containers are used to execute services, interfaces must be protected against threats or unauthorized access. Zero-trust principles will be important to creating a chain of trust that allows verification of authenticity for every physical hardware component and instance of a software process that is employed.

Security, reliability, and privacy needs will have to adapt to the needs of the use case, the energy available in devices for complex tasks, and the critical aspect of the use case. In this regard, there may be a need for higher complexity in certain environments that demand higher performance.

The next sections describe some of the key technologies considered essential to build a trustworthy 6G system. In the choices around how the technologies are applied, zero-trust principles are increasingly playing a role to select appropriate solutions and to realize the necessary verifications that form the basis of trustworthiness of these solutions.

6.1 PHY/MAC Security

Physical-layer security refers to a family of information-theoretic and signal processing methods that prevent unauthorized users from decoding wireless transmissions intended for other receiver(s) without relying on a pre-shared encryption key. In the context of cellular networks, PHY security is broadened to include anti-jamming and authentication measures. MAC security covers cross-layer extensions to protocol layers above the PHY, such as resource allocation and scheduling.

Augmenting security in 6G compared to existing authentication and key agreement methods is an important area of research, considering the increasing number and

variety of attacks that target the radio layer or disaggregated interfaces like fronthaul. A number of improvements and strategies can be considered in the objectives, such as to enhance data security, facilitate the detection of wireless jammers, and to improve the resiliency of the 6G radio to Denial of Service (DoS), spoofing, and tampering attacks with respect to the previous radio generations.

As shown in Figure 6.1, PHY security can reduce the data interception probability at eavesdroppers via specially designed beamforming and MIMO precoding methods.

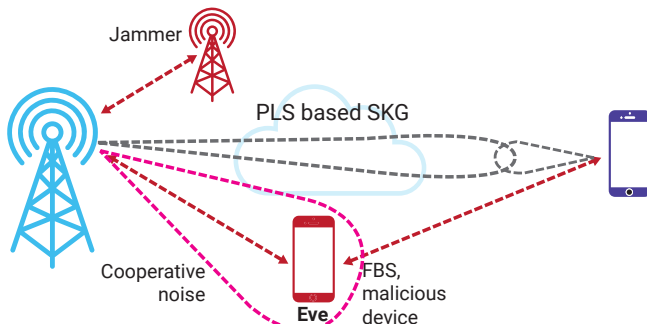

Figure 6.1: Exemplary Depiction of Physical Layer Threats and Mitigation Techniques

Alternately, the intrinsic randomness of the radio channel may be used to provide additional means of dynamically generating encryption keys and authenticating users. Symmetrical key generation based on fingerprinting can provide complementary means to be implemented in certain devices (e.g., reduced capability sensors or SIM-less devices). However, a key challenge is the necessity for high-precision CSI at transmitters.

Figure 6.1 also shows a jammer. In this case, the challenge is to detect stealthy reactive jammers capable of listening to the victim system and adapting their strategy accordingly. These jammers are potentially capable of selectively attacking certain parts of the signal, and even modifying certain data sent on unprotected channels, or impersonating a BS or a UE (spoofing attack). In some cases, a defensive approach for tampering would consist in implementing robust integrity protection and encryption on the currently unprotected channels that typically are below the Protocol Data Convergence Protocol (PDCP) layer

It should be noted that the widespread deployment of massive MIMO technology is an asset for the detection, localization, and avoidance of jammers, provided that spectro-temporal analysis techniques are implemented in the equipment. The spatial rejection properties of massive MIMO can also be used to mitigate malicious interference.

6G will support several critical applications relying on localization. Providing positioning integrity for RAT dependent and independent methods is an emerging need.

PHY/MAC security adds an additional level of security for 6G. It can also be considered as a category of post-quantum Physical Layer Security (PLS) methods that can potentially have lower computational complexity when compared to cryptographic security methods because it does not rely on computational complexity of cryptographic methods. Some

of the considered methods impact the air interface in a significant way and are out of the 5G scope. Meanwhile the air interface of 6G is still to be defined, and therefore offers more possibilities.

Unlawful use of International Mobile Subscriber Identity (IMSI) catchers, which is prevented by the Subscription Concealed Identifier (SUCI) scheme specified in 5G, or rogue BSs has been an ongoing threat to national and personal security. These rogue BSs can lure user devices to camp on them, and then capture user information and position/location information, threatening user privacy and safety. In addition, rogue BSs, with Man-in-the-Middle (MITM) attack techniques, can force a mobile device to downgrade from a more secure cellular generation or configuration to a less secure generation or configuration, allowing the attacker to eavesdrop or disrupt user communications. Other threats from a rogue BS include conducting user network slice traceability, building a user identification database, and building a user device model database.

By definition, user data communications between the mobile devices and the network will not start, and a security context will not be established, until the identity of mobile devices is authenticated and authorized. As a result, until primary authentication is completed and security is enabled, broadcast information (such as master information blocks and system information blocks) from the BS cannot be protected (e.g., integrity), nor can a user's unicast signalling messages be protected (e.g., confidentiality), which rogue BSs can exploit.

5G started the path of leveraging Public Key Infrastructure (PKI), such as in SUCI encryption and Open Authorization (OAuth) 2.0 framework, but symmetric key system still remains. Almost all data networking and web services technologies have adopted PKI with digital certificates and asymmetric key systems for security and authentication, with cellular networks a notable exception. It is imperative for 6G to adapt to any vulnerabilities exposed by reliance on symmetric key systems. One alternative is the potential use of asymmetric cryptography systems. Also, the asymmetric key systems in the PKI must use quantum-resistant/anti-quantum cryptographic systems.

It is expected that PHY/MAC security may be major contributors to Trust, Security, and Resilience as well as Security and Privacy as they are the first line of defense to provide security by leveraging the randomness inherent in noisy wireless channels.

6.2 Quantum Security and Post-Quantum Cryptographic Techniques

The security level of any cryptographic method depends on the key length and mathematical complexity of the algorithm used in the secret key generation for message encryption or authentication. The conventional security mechanisms heavily rely on public key cryptography, whose security depends on the associated mathematical problems of integer factorization,

discrete logarithms etc. Quantum computing allows the solution of certain hard mathematical problems (e.g., factorization) at a scale that decreases the time for solution exponentially in relation to linear increase in the number of processors and storage. This can potentially make classical public key cryptographic techniques vulnerable to attackers who have access to quantum computers of sufficient power.

While the state of the art of quantum computing is not at the level needed to currently pose a threat, 6G technologies should anticipate advances within the lifecycle. Therefore, 6G systems have to be specified with Post-Quantum Cryptography (PQC), authentication, and integrity protection. The goal of PQC (e.g., quantum-resistant cryptography) is to develop cryptographic systems that are secure against both quantum and classical computers and can interoperate with existing communication protocols and networks. National Institute of Standards and Technology (NIST) has initiated a process to evaluate and standardize quantum-resistant public-key cryptographic algorithms [27]. IETF is addressing different aspects of using PQC solutions in its working groups [28].

- > Fronthaul between RU and the Distributed Unit (DU) of the radio access, where the transport network of the fronthaul can be deployed in a point-to-point mode [29].
- > Backhaul between RAN (e.g., CU) and CN, etc.

Each bit of information is a pulse (e.g., a single photon) that is transmitted (via an optical/quantum channel e.g., optical fiber) to the receiver [30]. Its interception by any eavesdropper will necessarily translate into a perturbation, leading to errors in the bits exchanged, allowing the genuine ones to validate and identify if the key is secure. QKD is dependent on physical hardware, and suitable for fiber Ethernet, but it cannot be deployed on Wi-Fi, copper Ethernet, or other microwave-based technologies. The QKD rate is a key performance metric to be considered because the error rate impacts the key.

Although PQC is promising, a deep-dive interoperability analysis is required to identify how the PQC algorithms can complement or impact the existing key sharing and authentication method such as Transport Layer Security (TLS). It is crucial for the business world to evaluate early enough the impact of PQC in its business processes and product design lifecycle to avoid security breaches, delays, and issues with product development, and operational processes later on. Further research can consider hybrid key sharing techniques based on quantum and classical cryptography (e.g., PKI), as well as post-quantum protocol candidates, implementation of post-

quantum validation tools, designing cryptography based on code, lattices, multivariate cryptography, and isogeny, developing hardware that will accelerate existing PQC algorithm performance, designing a reliable quantum communication network.

Additionally, other services should be considered such as entropy as a service, which is a cloud architecture for distributing random

numbers through a quantum random number generator from multiple sources of entropy. This enables entropy-poor or constrained devices, such as IoT devices, to generate strong and unpredictable keys. Furthermore, the realization of quantum entangled networks is potentially feasible within the 6G timeframe. A quantum entangled network is one that makes use of quantum teleportation which uses the property of entanglement from quantum mechanics in order to securely transmit data between endpoints.

The research area prioritization for North America leadership can take into account the National Quantum Initiative reports [31] and perform early evaluation of hardware and software performance impacts with PQC, QKD, and other approaches to identify and prioritize 6G applications that can benefit from these technologies and avoid misuse of these technologies leading to security weakness or complexity at the system level. Regardless

The absolute randomness, reliability, and security of a cryptographic key improves with quantum key distribution as the intrinsic randomness of the photons is guaranteed by the fundamental law of physics. Quantum physics formally proves that interception of key without perturbation is impossible.

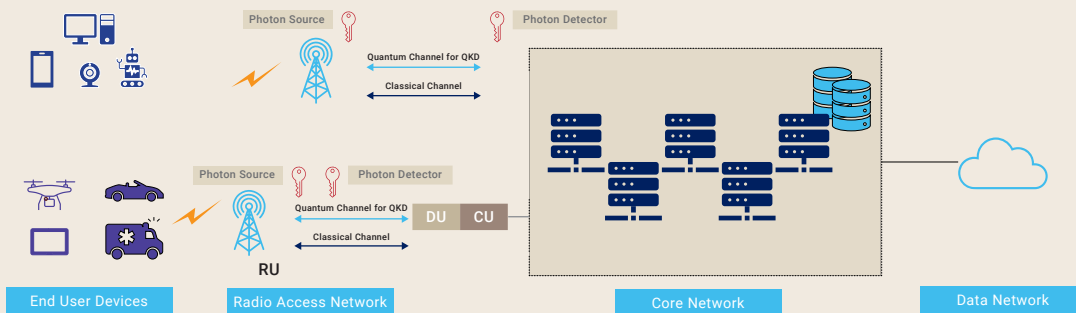

Figure 6.2: Application of Quantum Key Distribution

The adoption of quantum secure mechanisms leveraging PQC can largely benefit the 6G system, which involves different stakeholders such as millions of devices, different network products, and vertical service providers by enabling quantum-resistant security and assists service trust and reliability among the involved stakeholders. Quantum cryptography solves the problem of key distribution by allowing the cryptographic key exchange to occur using principles from quantum mechanics (such as the no-cloning principle), which guarantees security.

One such application is Quantum Key Distribution (QKD), a photonic technology, which can be considered in addition to PKI. A few QKD example applications are shown in Figure 6.2, such as for:

of the chosen technologies, implementation should be done in a crypto-agile fashion such that the accommodation of new PQC algorithms have minimal to no impact on the infrastructure while also providing the flexibility for future changes in case new vulnerabilities are discovered. Besides the agility, 6G standardization has to accommodate gradual adoption of the new technologies to have a controlled transition that secures both interoperability and security with respect to retained data.

6.3 Confidential Computation and Storage for Proprietary AI Models for Network Clouds

6G systems will integrate AI capabilities into computational fabric enabled by distributed cloud functionality by allowing developers to implement or avail of ML capabilities in service flows. These models will often be realized using proprietary data, data collected from devices, and the implementation of algorithms within the models that will rely on data that was processed offline. Models will need to be stored and updated, often within native cloud hardware provided by the operator or a hyperscale provider. These frameworks would offer the ability to do various ML computations. The cloud infrastructure would support data collection/storage, ML, training, AI reasoning, and model management/distribution. It is apparent that the AI capabilities can also be used for network operational efficiency, as the operator employs these frameworks to improve the network's performance toward specific objectives associated with the improvement of KPIs.

The support of diverse objectives for native AI technologies in 6G will need a new approach to compute architecture that provides data isolation between services and workflows and the availability of confidential computation resources. Thus, proprietary data would be isolated within confidential computing hardware, possibly with strong authentication and application of proprietary models within Trusted Execution Environments (TEEs).

The growing impact of AI-based processes raises a set of risks and concerns. The point behind confidential computing is to avoid the exploitation of data by malicious actors or opportunistic stealing of data. The protection is necessary mainly for services. If the role of AI were merely network optimization, current techniques for network design are quite good at isolating operator systems from hacking. Thus, verifying and validating ML models for intelligent network design should get utmost importance because this might lead to errors in network operations or the security breach of learning-based systems. Here, ensuring the trustworthiness of confidential computing is a multidimensional problem (e.g., designing efficient distributed systems, withstanding the adversarial data during model training, and verifying various properties of ML models to check if the models are behaving properly to achieve desired network performance). The formal method techniques can help the developers specify the system mathematically and verify various specifications of the systems. However, the existing Boolean satisfiability (SAT) solvers, Binary Decision Diagrams (BDDs), or Satisfiability Modulo Theories (SMT) solver would not be adequate to find various vulnerabilities of the learning models. Therefore, research on verified AI using formal methods tries to solve

the abovementioned issue using quantitative verification and compositional reasoning. Furthermore, to ensure the worthiness of the data being used by the ML approaches, adversarial ML techniques are currently being explored.

Another use for AI in 6G is if the operator provides access to sensing data that is generated by ancillary sensory facilities built into the network. How does a requesting NF or service component get authorized to access that data and use it within AI frameworks to generate its own inferences, while keeping ownership of the intellectual property around its own secret source? In this respect, the question of data integrity, anonymization/privacy issues, and possible unnoticed bias of the data, need to be addressed. Additionally, compliance must be addressed with regulations (e.g., General Data Protection Regulation (GDPR)).

The following research areas must be considered:

- > Developing computationally efficient and energy efficient federated learning algorithms to train a model across multiple decentralized edge devices or servers using local data samples.
- > Designing secure multi-party computation to enable multiple parties to collaborate to compute a common function of interest without revealing their confidential data to other parties and thereby realize authorization involving multiple players according to zero-trust principles.
- > Exploring the role of adversarial ML in confidential computation.
- > Exploring the use of various verifiable AI-based tools to identify possible vulnerabilities.

6.4 Data Provenance

Secure data provenance is crucial for data accountability and forensics. Data provenance essentially means the lineage of a data record is understood, including place and time of origin, modifications made to the data, the purpose of the data, who recorded it, and for whom it was produced. It is a measure of the authenticity of the data, and a statement that allows knowledge of its reproducibility and validity. Secure data provenance in the 6G system can ensure that a relying party like an internet-of-senses provider or an IoT service availing of 6G edge cloud services can be confident about what they receive from a device.

6G aims to integrate AI capabilities, which can automate and optimize network performance at all levels while maintaining a sufficient level of reliability, trustworthiness, and data privacy. Here, the AI-based techniques would be based on data sample points. Thus, it is essential to ensure that the correct data should be collected and processed to derive crucial insights about the state of the network and dynamic network operation. Hence, system designers need to ensure that the data is generated from the correct data sources

(e.g., the root of trust) and comes from suitable data storage systems (e.g., the chain of trust). One way of achieving a secure chain of trust is to design 6G with a hardware root of trust providing integrity and to employ mechanisms that provide data and code security for deployment over otherwise untrusted components. Similarly, to provide chain of trust, 6G may also rely on blockchain or Distributed Ledger (DLT) systems to decentralize security and privacy controls. Further study is needed in these areas.

Data provenance can be seen as the whole process information of data generation and evolution over time, including the static origins of data and their dynamic evolution. It enables to access the quality and trustworthiness of data.

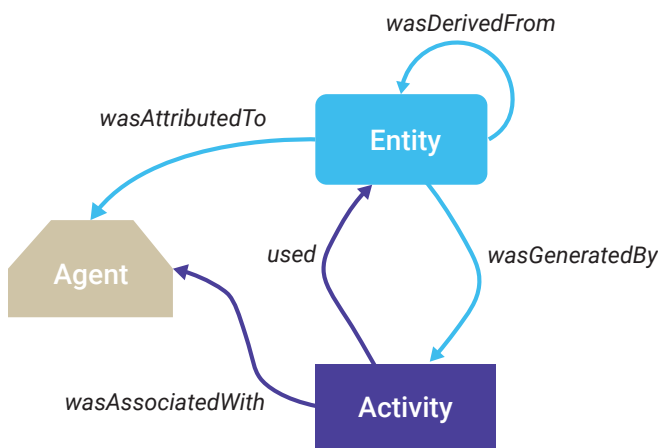

Figure 6.2: Application of Quantum Key Distribution

The provenance of generated data (root of trust): A

NIST team has been exploring physical measurements to ensure that the hardware systems are free of counterfeit components with vulnerabilities or poor-quality components. Counterfeit or faulty components may cause data loss, modification or disruption, unanticipated failures, and loss of system availability. Trust technologies such as secure enclaves (e.g., Trusted Platform Module (TPM) and TEE)) will protect data integrity and provide proof-of-data ownership anchored in silicon and hardware. In addition, blockchain technology and attestation mechanisms will continue to support distributed data brokerage by securely tracking data access rights.

The provenance of stored data (chain of trust): It is expected that many services and network operations will increasingly rely on centralized cloud computing, as well as edge computing capabilities, in the next generation of ICT technologies. It is therefore expected that large amounts of data generated by the networking infrastructure would be stored and processed within the distributed computational resources in the network. Consequently, there is a need to ensure cloud data provenance. A proper solution to the chain-of-trust problem must provide tamper-proof records, enable the transparency of data accountability in the cloud, as well

as at the edge, and provide for both privacy and availability of provenance data.

To enable data provenance in 6G, the TPM will provide secure storage of keys, confidential data, certificates, cryptographic measurements of system components, cryptographic functions, and key generation. The use of DLTs in 6G can play a role in the development of trust-based secure 6G networks. Properties of blockchain — such as immutability, provenance, non-repudiation, decentralized trust, and transparency — can help achieve various trust-based secure 6G networks requirements. Additionally, blockchain promises to solve issues like exclusive peer-to-peer transactions without centralized third parties, fraudulent replication of digital asset/value or transaction (e.g., double spending), establishing trust with pseudonymity, transparent yet immutable record-keeping, provenance and auditable enabled DLT, and digital signing and execution of legal agreements (between parties) in the form of digital or software-enabled contracts.

To realize the full potential of data provenance in 6G network the following research areas need to be explored:

- > Designing robust TPM to ensure trustworthy hardware-level isolation from the rest of the processing system.
- > Enabling secure boot and TEE to provide a secure area on a chipset that is used for isolating computations.
- > Developing device hardware and software attestation schemes to verify the authenticity and integrity of the hardware and software of a device.
- > Integrating DLT to increase decentralization functionalities.

6.5 Secure Identities, Data, and Protocols

A secure, resilient, and privacy-preserving network platform is a cornerstone in supporting the most demanding society, mission, and business-critical use cases with proven performance, under harsh conditions, in a verifiable way. As part of the privacy-preserving aspects of 6G, attention must be given to secure identities, data encryption, and secure protocols when invoking functions and their interfaces.

In addition to using temporary identifiers between mobile devices and the network, 3GPP has developed a capability for securing permanent identifiers over the airlink with 5G. The SUCI is a probabilistic encryption of the Subscription Permanent Identifier (SUPI) allocated to each subscriber. The SUCI is generated afresh on each UE invocation, making it very challenging to track mobile users in the network. It is worth investigating whether these approaches to identity management, with temporary or essentially ephemeral identifiers, can be further extended to all cloud components in the network. Thus, identifiers for virtual components,

such as containers or virtual machines, NFs, and interfaces used by instantiation of software on behalf of service chains can be hidden from casual inspection. Meanwhile, paths to software components can be changed periodically to prevent malicious actors from exploiting side-channel attack vulnerabilities. The complexity of such functionality can be addressed by means of specialized service handling that can be invoked.

Secure protocols can have several levels of encapsulation that serve to hide unauthorized exposure of identities or data. Tunnels between components should therefore be secure and access management mechanisms should disallow unauthorized exposure of identities and data.

Beside identifiers associated with network users (humans and devices), identifiers have become crucial for implementing zero-trust solutions in modern IT systems that use microservices, cloud-native application development, containers, and virtualization technologies. Authenticated and encrypted channels must be used between the components (e.g., containers)

from which NFs are built. In turn, these NFs must be connected by authenticated and encrypted channels to build an end-to-end mobile network. This requires that processing of data and storage of keys for identifiers are orchestrated so they are handled only by verified and authorized software within hardware components. Hardware, virtual machines, and associated software functions employed by a network flow, or a network slice should be verified and validated through a chain of trust to a trusted anchor. Verification should be completed within secure environments such as a TPM or a TEE. Messages used to derive authenticity via a chain of trust should be carried across reliable links.

Additionally, secure, and privacy-preserving mechanisms should be put in place for collecting, processing, analysing (using ML/AI or others), and storing the data collected about network users and virtual components for the sake of analysis or decision making (either internally or by a third party). Those mechanisms should achieve the right level of privacy while guarantying the desired level of utility, which is often application-specific.

The role of network softwarization in 6G is expected to further increase. Software will make their APIs available to



Figure 6.5: Secure Identity Management Framework

enable SDN and NVF capabilities. Any exposure of critical API of unintended software may lead to security threats. In this context, centralization of the network control will lead to centralized failure and may be subject to DoS attacks. As 6G will be more decentralized, many of the operations would involve decentralized means of identification, such as Decentralized Identifiers (DID) and SSI. These techniques will enable users and organizations to own their digital identities without any intermediate central authority. In addition, novel secure mutual authentication between network entities and cross-domain identity management in 6G will help distribute governance across various trust domains. Furthermore, the high demand for URLLC application that is defined in 3GPP Release 16 will require a trustable and reliable orchestration of NFs (physical and virtual) transitioning between edge and cloud environments. Management mechanisms to verify, validate, and authorize the required NF instances becomes fundamentally important to guarantee resilience and trustworthiness in the end-to-end network infrastructure.

From a North American leadership perspective, the following research areas can be explored:

- > Storage and processing solutions for identification management.
- > Analyzing workflows for key security metrics.
- > Defining threat detection and response in cloud-based identifiers.
- > Designing low energy-consumption distributed identity management schemes.
- > Identifying the impact of central actors in decentralized systems.
- > Ensuring guaranteed speed and scalability for distributed secure protocols, such as access control based on encoded agreements around automated contractual rules for primary and secondary authentication.
- > Enhancing the PKI certificate management eco-system, especially pertaining to certificate management designed for web access (and web trust models).

6.6 Automated Closed Loop Security Creation

A comprehensive security architecture must implement the NIST principles of identification, protection, detection, response, and recovery functions. Automated closed loop security is one aspect of serving these five functions in the design of a resilient network.

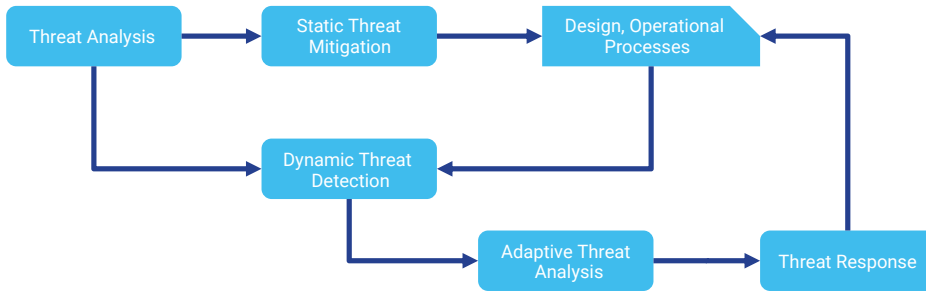

Figure 6.6: Illustration of Automated Closed Loop Security Procedures as a Process

Automated closed loop security mechanisms are built from the following basic building blocks as shown in Figure 6.6:

- > **Threat analysis:** This starts with the identification of security requirements – static and dynamic – and the method of addressing the external and internal threats that can compromise the security of systems. It may be necessary to qualify the analysis against the needs of specific use cases. Additionally, threat surfaces can evolve as attackers grow more sophisticated and new features are developed; dynamic threat analysis will be essential to anomaly detection.
- > **Static threat mitigation:** Some threats are organizational, implementational, or architectural and can be addressed by means of solutions that arise from the threat analysis of a system. Such threats can be addressed by means of attestation of compliance to structured design techniques and process mechanisms.
- > **Threat detection:** Dynamic threats are based on the possible exposure of the system to concerted, often intelligent, attacks by malicious actors. Such threats can partially be mitigated by understanding typical methods of detection of known threats. In addition, a change in behavior or environment can be used to also identify unknown threats by means of the effect of those threats on system performance. In such cases, active monitoring of key metrics could be analyzed on a real-time basis, with the assistance of ML, to detect anomalies.
- > **Threat response:** Automation of responses to threats will depend on the use of programmed responses to known threats. Active threat-and-response simulation to characterize the attitude and impact of these threats and to identify mitigation conditions that affect system performance by unknown threats can be carried out. For example, electromagnetic threats may be identified and localized in an environment, prior to the system responding by instantiating redundant network nodes to alleviate the threat, or by instituting avoidance measures

through interference nulling. Similarly, denial-of-service attacks can be identified by detecting the occurrence of activity signatures that are typical of the slowing of traffic flows and their predominant causes. As a last resort, an automated system can also invoke human intervention in the loop.

A data-driven approach to security is made possible by the introduction of distributed computing. Open architectures for networks can expose interfaces that serve to aid security workflows.

End-to-end observability is not trivially implemented, and very often assumes wide-ranging accessibility of measurements at several sites within the network. Real-time observability may need handling and possible transport of data in manageable volumes, keeping the energy footprint and computational requirements within limits. An additional challenge lies in the assurance of the quality and integrity of the observations, leading to a need to use strong attestation mechanisms to implement zero-trust principles.

Research areas for closed loop security automation will start with an understanding of the various use cases and the degree to which security procedures can be integrated into mass market products in a cost-effective manner. Some use cases may involve specialized security procedures that are tailored to the specific deployment scenario or use case (e.g., industrial automation or public safety). A second research area would be to resolve the relative compatibility of procedures in 5G and 6G networks and the threats posed by backward compatibility. Observability at the component level and relating local observations to security analysis workflows for key metrics will be a key application area for data analysis and AI. Lastly, the division of automated response and the role of human interaction with automation is necessary to keep 6G systems reliable and free from exploitation of security response mechanisms themselves as a threat.

6.7 Security Assurance and Defense

A secure, resilient, and privacy-preserving network platform is a cornerstone in supporting the most demanding society, mission, and business-critical use cases with proven performance, under harsh conditions, in a verifiable way. Enhanced security and critical service assurance mechanisms, together with AI-based security and trust management, make it possible to respond in real time to known and unknown threats.

The 6G network will rely on greater degrees of observability of metrics and phenomena during operations.

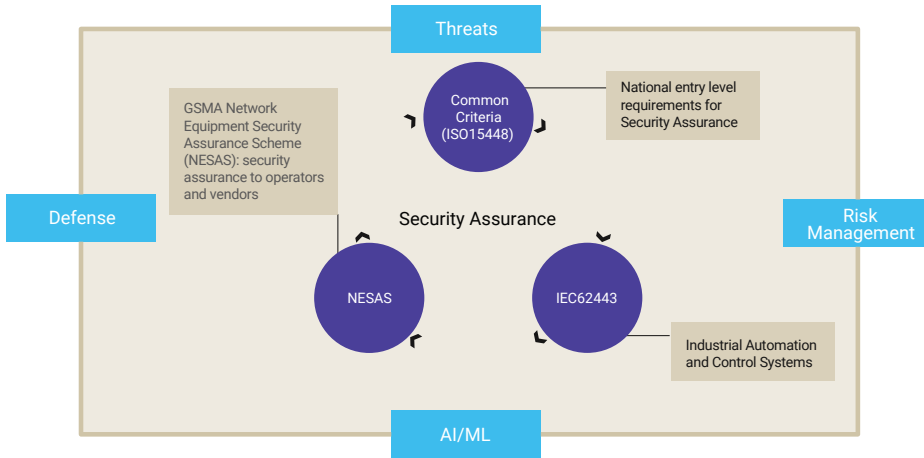

Figure 6.7: An example of the security assurance definitions relevant to the industrial automation use case, along with an illustration of the relationship of the threat landscape and associated defense mechanism to the role of risk management and AI/ML

Security assurance is a process in which arguments can be presented about underlying risks associated with products, software, or services, with associated certification processes. A commonly used assurance tool is based on Common Criteria (CC), featuring an increasing scale of evaluation assurance levels, balancing the level of assurance with the cost and feasibility of acquiring that degree of assurance. The Network Equipment Security Assurance Scheme (NESAS) is an industry-wide security assurance framework, jointly developed by 3GPP and the Global System for Mobile communications Association (GSMA). It defines security requirements and an assessment framework for secure product development and product lifecycle processes and uses security test cases for the security evaluation of 5G equipment. This framework can be extended for 6G as needed to include the risks associated with various new service classes.

Critical infrastructure like power grids, financial institutions, and even governmental networks are all becoming increasingly connected and more reliant on IT systems. And for that, there is a need to define the requirements of security assurance. An example of such a requirement is the need for many layers of complexity and diverse methods of linking to common objectives; this must be balanced against the complexity that can be borne by the application. Security assurance and defense is highly dependent on end-to-end considerations that span all aspects of trustworthiness, including network reliability and resilience. Network complexity and the intended uses of 5G and future networks offer opportunities of automation techniques using AI/ML. ML methods can be investigated to analyze and verify compliance with security requirements. Similarly, AI/ML

techniques must themselves be designed in a way where results can be explained, and automation can be trusted to meet the design objectives. The range of possible known attacks

In 6G networks, security assurance and defense will be bolstered by the availability of data-driven approaches and the use of ML frameworks that mitigate risks on a real-time basis.

against the system(s) and measure of how many, and which, relevant security controls have been implemented out of a known set such as that defined in [32] should be considered when measuring defences.

The European Union Agency for Cybersecurity (ENISA) has the charter for achieving a high common level of cybersecurity across Europe. The agency is creating a series of recommendations on aspects of security assurance [33] that go beyond the remit of NESAS and address aspects such as:

- > Governance and risk management
- > Human resources security
- > Security of systems and facilities
- > Operations management
- > Incident management
- > Business continuity management
- > Monitoring, auditing, and testing
- > Threat awareness

In 6G networks, this methodology will be bolstered by the availability of data-driven approaches and the use of ML frameworks that mitigate risks on a real-time basis.

The main advantage of a comprehensive security assurance and defense approach for 6G is the potential for use of automation across network operations and frameworks made available to services to mount an effective defence against anomalies, disturbances, and threats.

Deployment profiles for 5G and 6G are likely to vary a lot. These will depend on the nature of the use case, whether applied for public consumption or for enterprise/vertical use, the degree of control that the service provider or end user has over the network configuration, and the timeliness of the defense mechanisms being used.

Some of the areas for research are use case requirements, automation of service availability and security, observability of RAN and network performance, workflows for analysis of key security metrics, and threat detection and response.

6.8 Service Availability Enablers

The service availability goal is specifically oriented toward network reliability and resilience, with the reliability of the radio network being of specific importance. In 5G and 6G,

support of use cases around industrial automation and other mission-critical applications drives research into resource provisioning throughout the connectivity layer, RAN and Core included. Services require an assurance that their application performance needs can be adequately met, even when faced with threats on the radio link, such as jamming. In the case of emergencies such as disasters, networks must be able to garner resources for critical services, while automation of industrial processes must react to faults and disturbances in a way that preserves system components and provides safety. Services availing of connectivity should be capable of monitoring the SLAs. The service-based architecture should expose information that adequately demonstrates the reliability of the network. This “trust but verify” approach allows the establishment of a technical solution to risk mitigation and provides confidence that problems can be identified and mitigated, even if not resolved completely. The exposure of performance monitoring information even within the network aids automation of incident handling and recovery mechanisms. Lastly, the use of digital twins employing threat simulation can be an operational feature will improve the attitude of networks towards diverse requirements.

Improving 6G service availability revolves around the use of data-driven techniques that increase the internal observability of network state, associated with the concurrent use of AI/ML.

Existing mechanisms designed and deployed for eMBB include aspects such as network node pooling, geographical redundancy, and solutions with multiple frequency bands and multiple cells that provide an abundance of resources. Multiple RAT (multi-RAT) can provide redundancy, as well, with different complementing access technologies. These mechanisms are becoming increasingly important for new use cases where requirements on performance and service quality must be verified. An example is when robots are used in conjunction with wireless automation, functional safety requirements call for redundant radio connectivity options for diversity and link reliability.

Among other issues, jitter and latency can affect critical path deadlines in a manufacturing or assembly line, allowing, for example, race conditions to interfere with the integrity of a process control system. While higher reliability and lower latency requirements typically come at a cost to capacity and throughput, the 5G system is designed to allow flexibility in configuring radio bearers to meet controllable performance requirements while continuing to evolve to address new requirements. This general philosophy must continue for 6G, with broad-based analysis of critical automation in enterprises, wide-area use cases such as utilities, transportation, and public safety, etc.

Improving service availability revolves around the use of data-driven techniques that increase the internal observability of network state, associated with the concurrent use of AI/ML to generate metrics for performance that are then exposed to the service layer for feedback and control.

Already in the evolution of 5G, it will be possible to implement automation across network operations and frameworks to predict risks to network planning, resource provisioning, and service availability. With 6G, it will be easier to implement new functionality that includes resource provisioning at the UE, without significant worry about the constraints of legacy systems, especially on the device.

Challenges around service availability span all parts of the network:

- > Coverage provisioning.
- > Peak load handling.
- > Dependability of hardware and software.
- > Avoiding Single Points of Failure (SPoF) in equipment and deployment profile across RAN, transport, Core, and cloud.
- > Performance management across all network components.
- > Continuous Improvement/Continuous Development (CI/CD) approaches to network performance improvement.
- > Additionally, the limitations of legacy systems will need to be factored into the impact on service availability from a holistic perspective.

Some of the important research areas are:

- > Performance management for RAN, transport, Core, cloud components, and applications.
- > Observability of RAN and network performance.
- > Local survivability of networks in disaster and public safety scenarios.
- > Availability-aware service placement and service chain orchestration techniques.
- > Service availability in Software-Defined Optical Networks.

6.9

Section Summary and Recommendations

The previous sections have identified several technologies that are expected to be key in ensuring 6G is trustworthy.

PHY/MAC security and quantum/post-quantum security are steps that must be taken to ensure that the system is secure against the ever-increasing sophistication and computational power of adversaries.

Ever-increasing use of AI and harvesting of data (both by applications and the network) requires better ways to protect the data and AI models. Strong protection is needed not just for privacy, but because the network, and in many cases critical applications, are only as reliable as the data they consume.

For reliability and availability, new tools are needed to allow the system to learn, detect, and respond to threats autonomously. AI will play a key role in ensuring network trustworthiness, but research is needed to ensure that errant AI is not the cause of failure or degradation.

7 SUMMARY

Technology has been fueling the exponential growth of the world economy over the past few centuries. 6G technology is expected to usher in the next wave of digital economic growth, as well as drive far-reaching societal shifts in sustainability, digital equality, trust, and quality of life. This report identifies and highlights high-impact 6G research areas in component technologies, radio technologies, AI/ML, network architecture and topology evolution, OA&M and service enablement, and security/trustworthiness. To illustrate why extensive investments and R&D in these areas are crucial to ensure the North American 6G leadership, this paper provides a brief recap below on the critical roles played by each technology.

Advanced Component Technologies

Advancements in component technologies in the semiconductor industry will serve as the cornerstones for 6G due to their strategic importance across multiple industries and sectors and its long investment/life cycle. Increased investment in semiconductor research to strengthen the resilience of the supply chain for critical semiconductor infrastructure onshore for the 6G ecosystem is key for the U.S. to be competitive in the 6G era. Science and technology development in basic material, device science, circuits and systems, and large-scale advanced manufacturing capabilities will have profound impacts on various aspects of the 6G ecosystem. These include:

- > Enabling new 6G frequency bands based on advanced semiconductor packaging, RF components, and antenna technologies.
- > Empowering baseband modems for exponential data rate scaling while maintaining high processing power efficiency.
- > Creating new varieties of device types (e.g., XR glasses/devices, holographic display) of diverse form factors and use cases.
- > Achieving ubiquitous 6G connectivity for various applications.
- > Data centers in the cloud.

Meanwhile, it is also important to increase federal investment in research and ecosystem, pertaining to the use of microelectronics for advanced wireless communications to create research prototyping platforms. Another key area is creating an engineering talent pipeline among students in STEM fields.

Fundamental Radio Technologies

The evolution in basic radio technologies is the most fundamental aspect of the next-generation cellular systems having a direct impact on canonical system KPIs. Various enhanced/ultra-Mobile Broadband services (eMBB/uMBB) can be realized thanks to continued wireless technology evolution in 6G. 6G is expected to expand into new spectrum frequencies (e.g., sub-THz/THz bands) to meet higher data rates and more diverse new applications. A big part of the new radio technology design will be geared toward efficient utilization of the spectrum in the new (higher) bands. Radio waves in high-frequency bands (such as mmWave, sub-THz/THz spectrum) can be used for communication and for RF sensing purposes for situational awareness, which may benefit new use cases such as autonomous driving and XR, etc. With integrated support of joint communication and sensing in cellular systems, new business opportunities could bloom in the 6G era. Design evolution/enhancement for existing bands — such as a new air-interface design for mmWave and/or sub-7 GHz — are also expected in 6G via technologies like spectrum sharing, massive spectrum aggregation, and flexible duplex/full duplex technologies, etc.

Moreover, various technological advancements in MIMO — including RIS, OAM, advanced massive MIMO, distributed MIMO as well as fundamental physical layer building blocks such as waveform, coding, modulation, and multiple-access schemes — will further improve the actual end user experience performance in 6G across new bands and existing bands. Spectrum efficiency will no longer be the only driving metric in the 6G RAN design. Green radio networks, energy-efficient devices, and NZE communication technologies will contribute to achieving end-to-end power efficiency in 6G wireless systems, from network to devices and enabling new types of low-power devices.

AI/ML

6G will be the era of mobile intelligence much like 4G was the age of mobile Internet. AI/ML is expected to penetrate every layer of the 6G ecosystem. AI/ML will become a key technology to realize the 6G vision of enabling a fully autonomous network operation and automation with extreme flexibility to achieve dynamic network and air interface adaptation. All of this will be key for serving a much more diverse set of use cases while substantially improving network operation efficiency. More fundamentally, AI-based air interface design and air interface enablement for distributed computing and intelligence will allow end-to-end native AI and true convergence of communication and computing during 6G time. AI/ML will also play a key role in ensuring network security and trustworthiness by allowing the system to learn, detect, and respond to threats autonomously.

Network Architecture, OAM, and Network Topology Evolution

In 6G, network architecture evolution may follow the general trend in the Internet network architecture evolution toward a cloud-native network design. The rigid split of function layers must be replaced by a more flexible architecture considering UE/Core/RAN joint design and protocols that accommodate the diverse environments and services that 6G will demand with a more modular service-oriented design. The boundaries on where computing happens will dissolve with computing and data storage occurring where it makes sense. Thanks to the maturity of wired/wireless backhaul technologies, the migration of 6G Core/upper RAN into the cloud for a fully virtualized 6G CN and upper RAN will be realized. This achieves efficient computation resource pooling, facilitating 6G OA&M for full end-to-end autonomy, automation, and dynamic orchestration, management, and coordination across different functional blocks. It also helps to build and maintain a green 6G network.

Based on the new 6G network architecture, radio technologies for new topology and networking are expected to evolve more flexibly to support various new types of connectivity. They also will continuously evolve to provide adaptive network coverage to meet the varying user traffic demand and extremely wide coverage area requirements.

Traditional terrestrial concepts will be expanded with satellites and other aerial platforms to provide alternative coverage. Mesh networks and embedded subnetworks will be introduced that break the extend the cellular concept by adding new connectivity options. More diverse network topologies could prevail in the 6G era to enable true heterogeneous networks across various frequency bands, TN vs. NTN, and diverse network topologies.

Security/Trustworthiness

Finally, to establish the 6G cellular communication system as a fundamental, robust, and reliable infrastructure, security, and trustworthiness of 6G networks are critical. Quantum/post-quantum security is a forward-looking design to ensure security against disruptive quantum computing technologies and the computational power of adversaries in the next several decades. Upper layer security enhancements, in conjunction with potential new PHY/MAC security mechanisms, are expected to protect user security and privacy, as well as overall network security (by protecting the user data used for network-side training). Finally, identity management and/or data provenance technologies could potentially enable new classes of UEs such as low-power IoT devices to further expand the functionality of the 6G cellular network system.

8 REFERENCES

1. Next G Alliance Green G: The Path Toward Sustainable 6G, January 2022. https://nextgalliance.org/white_papers/green-g-the-path-towards-sustainable-6g/
2. Testimony of the Semiconductor Industry Association (SIA), House Permanent Select Committee on Intelligence Subcommittee on Strategic Technology and Advanced Research. <https://www.semiconductors.org/wp-content/uploads/2021/07/HPSCI-briefing-testimony-july-20-2021.pdf>
3. B. Heinemann et al., "SiGe HBT with f_T/f_{max} of 505 GHz/720 GHz," IEEE Int. Electron Devices Meeting (IEDM), December 2016.
4. M. Urteaga et al., "130nm InP DHBTs with $f_T > 0.52$ THz and $f_{max} > 1.1$ THz," 69th Annual IEEE Device Research Conference, pp. 281-282, June 2011.
5. "B. Murmann, "ADC Performance Survey 1997-2021". <https://web.stanford.edu/~murmman/adcsurvey.html>
6. V. Camarchia, R. Quaglia, A. Piacibello, D. P. Nguyen, H. Wang, and A.-V. Pham, "A review of technologies and design techniques of millimeter-wave power amplifiers," IEEE Transactions on Microwave Theory and Techniques, vol. 68, no. 7, pp. 2957–2983, 2020.
7. IEEE Electronic Packaging Society: Heterogeneous Integration Roadmap (2021 addition). <https://eps.ieee.org/technology/heterogeneous-integration-roadmap.html>
8. M.J.W.Rodwell, "Packaging challenges in 100-300GHz Wireless," 2021 3DIC IEEE International 3D systems Integration Conference", November 2021.
9. FG NET2030 Sub-G2, "New Services and Capabilities for Network 2030: Description, Technical Gap and Performance Target Analysis", ITU-T, October 2019.
10. Pierre-Alexandre Blanche. "Holography, and the future of 3D display", [J]. Light: Advanced Manufacturing. doi: 10.37188/lam.2021.028, December 2021.
11. "ITU Radio Regulations 2020". http://www.itu.int/dms_pub/itu-r/opb/reg/R-REG-RR-2020-ZPF-E.zip
12. Dajer, et al. "Reconfigurable intelligent surface: Design the channel—A new opportunity for future wireless networks." Digital Communications and Networks (2021).
13. Black, Eric J., "Holographic Beam Forming and MIMO", Pivotal Commware. <https://pivotalcommware.com/wp-content/uploads/2017/12/Holographic-Beamforming-WP-v.6C-FINAL.pdf>
14. Allen, L., et al., "Orbital angular-momentum of light and the transmission of Laguerre-Gaussian laser modes," in Phys. Rev. A 45, 8185-8189 (1992).
15. W. Cheng, W. Zhang, H. Jing, S. Gao and H. Zhang, "Orbital Angular Momentum for Wireless Communications," in IEEE Wireless Communications, vol. 26, no. 1, pp. 100-107, (2019).
16. Mark Patel, et al, "The Internet of Things: Catching up to an accelerating opportunity," McKinsey & Company, November 2021.

17. HEXA-X Project Deliverable D1.2: Expanded 6G vision, use cases and societal values.
18. "Extreme Communication in 6G: Vision and Challenges for 'in-X' Subnetworks", G. BERARDINELLI, et. al, IEEE open Journal of the Communication Society, vol. 2, 2021, pp. 2516 -2535.
19. "5 G Evolution and 6G", NTT DoCoMo, Inc, January 2020.
20. "Network 2030, a blueprint of technology, applications and market drivers towards the Year 2030 and Beyond", FG-NET-2030.
21. TR 38.811 "Study on NR to support non-terrestrial networks"
22. TR 38.821 "Solutions for NR to support non-terrestrial networks"
23. A. Rujis and A. Kumar, "Ambient Intelligence In day to day life: A survey," 2019 2nd International Conference on Intelligent Computing, Instrumentation and Control Technologies (ICICT), 2019, pp. 1695-1699, doi: 10.1109/ICICT46008.2019.8993193.
24. IST Advisory Group, Ambient Intelligence: From Vision to Reality, European Commission, 2003. <https://www.clubofamsterdam.com/content/articles/09%20Media%20Entertainment/Ambient%20Intelligence.pdf>
25. K.-D. Lee, "A Smart Network of Service Robots: Technical Challenges and Design Considerations," IEEE Communications Magazine, Sept. 2021. <https://ieeexplore.ieee.org/abstract/document/9530489>
26. R. Adeogun, G. Berardinelli, P. E. Mogensen, I. Rodriguez, and M. Razzaghpour, "Towards 6G in-X subnetworks with sub-millisecond communication cycles and extreme reliability," IEEE Wireless Communications, vol. 18, no. 3, pp. 10-21, 2011.
27. Post-Quantum Cryptography Overview, NIST. <https://csrc.nist.gov/Projects/post-quantum-cryptography>
28. "Activity in Post-Quantum Cryptography. IETF." <https://trac.ietf.org/trac/sec/wiki/PQCAgility>
29. ITU-T, Series G, Supplement 67, 'Application of optical Transport Network Recommendations to 5G Transport', 2019.
30. Quantum Safe Security, IDQ Redefining Security, 2020.
31. National Quantum Initiative. <https://www.quantum.gov/>
32. NIST Privacy Framework and Cybersecurity Framework to NIST Special Publication 800-53, Revision 5 Crosswalk, December 2020.
33. ENISA, "5G Cybersecurity Standards: Analysis of standardization requirements in support of cybersecurity policy," March 2022. <https://www.enisa.europa.eu/publications/5g-cybersecurity-standards/@@download/fullReport>

9 ABBREVIATIONS

3GPP	The 3rd Generation Partnership Project
5G	fifth generation
6G	sixth generation
ADC	Analog-to-Digital Converter
AI	Artificial Intelligence
AiP	Antenna-in-Package
Aml	Ambient Intelligence
AoC	Antenna-on-Chip
API	Application Programming Interface
AR	Augmented Reality
BDD	Binary Decision Diagrams
BER	Bit Error Rate
BiCMOS	Bipolar CMOS
BS	Base Station
CAPEX	Capital Expenditure
CC	Common Criteria
CCRC	Continuing Care Retirement Community
CD	Continuous Development
CDMA	Code Division Multiple Access
CI	Continuous Improvement
CMOS	Complementary Metal-Oxide-Semiconductors
CN	Core Network
CPE	Customer Premises Equipment
CSI	Channel State Information
CSI-RS	CSI Reference Signal
CSMA/CA	Carrier Sense Multiple Access/Collision Avoidance
CU	Centralized Unit
D2D	Device to Device
DAC	Digital-to-Analog Converter
DARPA	Defense Advanced Research Projects Agency
DFT-s-OFDM	Discrete Fourier Transform Spread Orthogonal Frequency Division Multiplexing
DID	Decentralized Identifier
DL	Downlink
DLT	Distributed Ledger
DoS	Denial of Service

Notice of Disclaimer and Limitation of Liability

The information provided in this document is directed solely to professionals who have the appropriate degree of experience to understand and interpret its contents in accordance with generally accepted engineering or other professional standards and applicable regulations. No recommendation as to products or vendors is made or should be implied.

NO REPRESENTATION OR WARRANTY IS MADE THAT THE INFORMATION IS TECHNICALLY ACCURATE OR SUFFICIENT OR CONFORMS TO ANY STATUTE, GOVERNMENTAL RULE OR REGULATION, AND FURTHER, NO REPRESENTATION OR WARRANTY IS MADE OF MERCHANTABILITY OR FITNESS FOR ANY PARTICULAR PURPOSE OR AGAINST INFRINGEMENT OF INTELLECTUAL PROPERTY RIGHTS. ATIS SHALL NOT BE LIABLE, BEYOND THE AMOUNT OF ANY SUM RECEIVED IN PAYMENT BY ATIS FOR THIS DOCUMENT, AND IN NO EVENT SHALL ATIS BE LIABLE FOR LOST PROFITS OR OTHER INCIDENTAL OR CONSEQUENTIAL DAMAGES. ATIS EXPRESSLY ADVISES THAT ANY AND ALL USE OF OR RELIANCE UPON THE INFORMATION PROVIDED IN THIS DOCUMENT IS AT THE RISK OF THE USER.

NOTE - The user's attention is called to the possibility that compliance with this document may require use of an invention covered by patent rights. By publication of this document, no position is taken with respect to whether use of an invention covered by patent rights will be required, and if any such use is required no position is taken regarding the validity of this claim or any patent rights in connection therewith. Please refer to www.atis.org/legal/patentinfo.asp to determine if any statement has been filed by a patent holder indicating a willingness to grant a license either without compensation or on reasonable and non-discriminatory terms and conditions to applicants desiring to obtain a license.

Copyright Information

Copyright © 2022 by
Alliance for Telecommunications Industry Solutions

All rights reserved.

Alliance for Telecommunications Industry Solutions
1200 G Street, NW, Suite 500
Washington, DC 20005

No part of this publication may be reproduced in any form, in an electronic retrieval system or otherwise, without the prior written permission of the publisher. For information, contact ATIS at (202) 628-6380. ATIS is online at <http://www.atis.org>.

Building the foundation for
North American leadership in
6G and beyond.

nextgalliance.org

